

# GB172i-24 T50 .. / GB192i-24 T50 .. Logamax plus

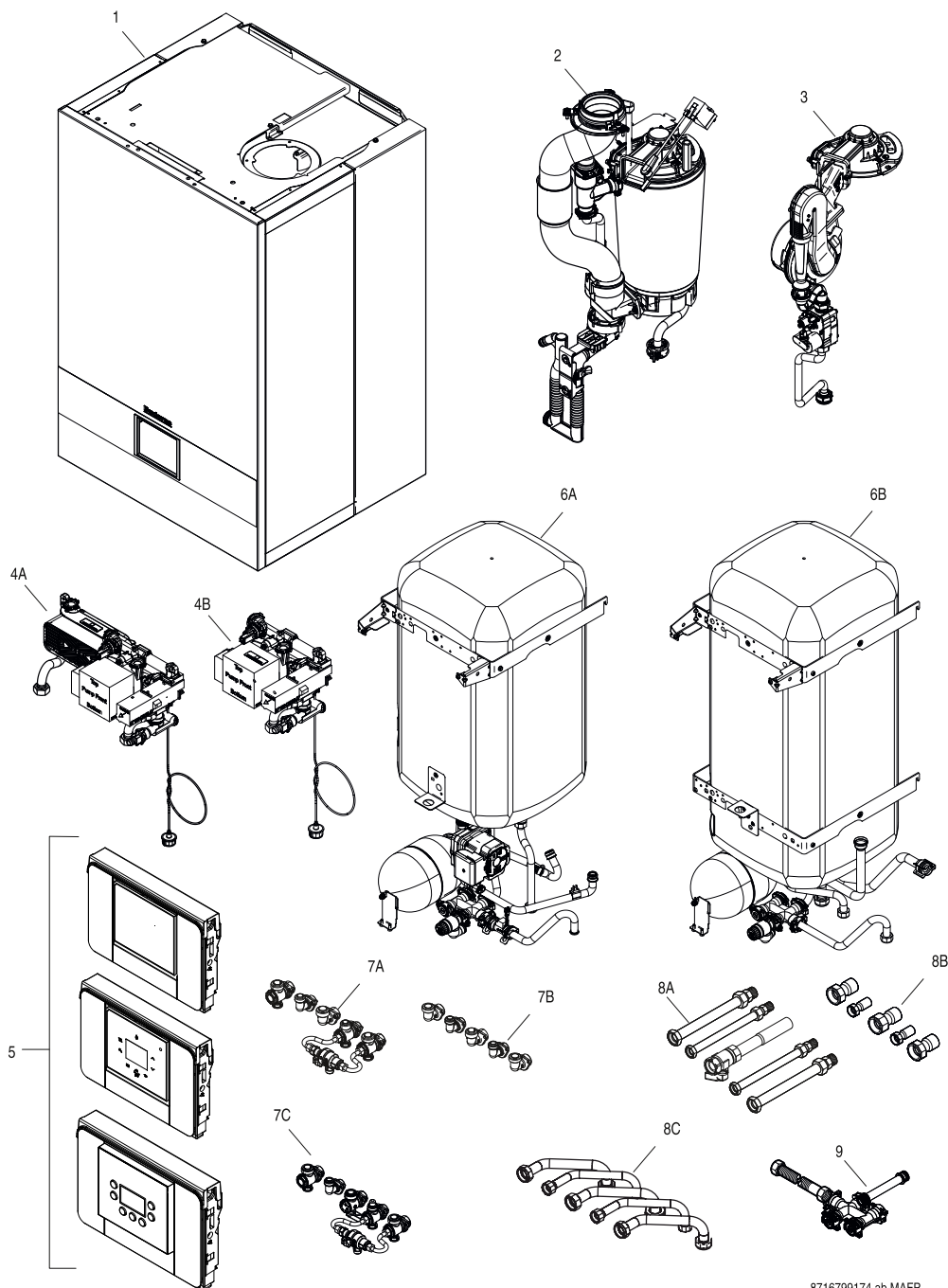

8716799174.ab.MAFP



**[de] Wichtige Hinweise zur Installation/Montage**

Die Installation/Montage muss durch eine für die Arbeiten zugelassene Fachkraft unter Beachtung der geltenden Vorschriften erfolgen.

**[en] Important notes on installation/assembly**

The installation/assembly must be carried out by a qualified contractor, following these instructions and in compliance with the applicable regulations.

**[fr] Instructions importantes pour l'installation/le montage**

L'installation/le montage doit être effectué(e) par un spécialiste qualifié pour les opérations concernées et dans le respect de la présente notice et des prescriptions applicables.

**[bg] Важни указания във връзка с инсталацията/монтажа**

Инсталацията/монтажът трябва да се извършва от лицензиран за работите специалист в съответствие с настоящото ръководство и с приложимите разпоредби.

**[cs] Důležité pokyny k instalaci/montáži**

Instalaci/montáž musí při dodržení pokynů uvedených v tomto návodu a platných předpisů provést odborný pracovník s příslušným oprávněním pro tyto práce.

**[da] Vigtige anvisninger til installationen/monteringen**

Installationen/monteringen skal foretages af en godkendt installatør under overholdelse af denne vejledning og de gældende forskrifter.

**[el] Σημαντικές υποδείξεις για την εγκατάσταση/συναρμολόγηση**

Η εγκατάσταση/τοποθέτηση πρέπει να ανατίθεται σε εκπαιδευμένο για τις συγκεκριμένες εργασίες τεχνικό προσωπικό με τήρηση αυτών των οδηγιών καθώς και των σχετικών προδιαγραφών.

**[es] Indicaciones importantes para instalación/montaje**

La instalación/el montaje debe realizarla personal especializado que esté autorizado para realizar estos trabajos y que tenga en cuenta estas instrucciones y la normativa vigente.

**[et] Olulised juhised paigaldamiseks/montaažiks**

Paigaldamist/montaaži tohib läbi viia vaid selleks volitusi omav spetsialist, arvestades kehtivaid nõudeid.

**[nl-BE] Belangrijke aanwijzingen betreffende de installatie/montage**

De installatie/montage moet worden uitgevoerd door een voor de werkzaamheden geautoriseerde installateur rekening houdend met deze handleiding en de geldende voorschriften.

**[fi] Tärkeitä asennus- ja kokoonpano-ohjeita**

Näihin töihin hyväksytyin ammattiasentajan pitää suorittaa asennus- ja kokoonpanotyöt voimassa olevien määräysten mukaisesti.

**[hu] Fontos tudnivalók az installáláshoz/szereléshez**

A telepítést/szerelést egy, a munkálatokra felhatalmazott szakembernek kell végeznie, jelen utasítás és az érvényes előírások figyelembevételével.

**[it] Avvertenze importanti per l'installazione/il montaggio**

L'installazione/il montaggio deve aver luogo ad opera di una ditta specializzata ed autorizzata in osservanza di queste istruzioni e delle direttive vigenti.

**[ka] მნიშვნელოვანი მითითებები ინსტალაციისთვის/მონტაჟისთვის**

ინსტალაცია/მონტაჟი უნდა განხორციელდეს საშუალებისთვის დამკვეთი კვალიფიციური პერსონალის მიერ, მოქმედი განაწესის დაცვით.

**[lt] Svarbios instaliavimo ir (arba) montavimo nuorodos**

Instaliavimo / montavimo darbus, laikydamiės šios instrukcijos reikalavimų ir galiojančių taisyklių, privalo atlikti šioms darbams įgalioti specialistai.

**[lv] Svarīgi norādījumi par iekārtas uzstādīšanu / montāžu**

Uzstādīšanu/montāžu jāveic atbilstošajiem darbiem sertificētam speciālistam, ievērojot šo instrukciju un spēkā esošos noteikumus.

**[nl] Belangrijke aanwijzingen betreffende de installatie/montage**

De installatie/montage moet door een erkend installateur volgens de geldende voorschriften worden uitgevoerd.

**[no] Viktig informasjon om installasjon/montering**

Installasjonen/monteringen skal gjennomføres av autoriserte installatører, og installasjonsanvisningen samt gjeldende forskrifter skal følges.

**[pl] Ważne wskazówki dotyczące instalacji/montażu**

Instalację/montaż powinien wykonać specjalista uprawniony do tego typu prac z uwzględnieniem informacji podanych w niniejszej instrukcji oraz aktualnie obowiązujących przepisów.

**[pt] Indicações importantes relativas à instalação/montagem**

A instalação/montagem deve ser efectuada por um técnico autorizado para os trabalhos, respeitando este manual e as prescrições válidas.

**[ro] Indicații importante privind instalarea/montajul**

Instalarea/montajul trebuie realizate de către un specialist autorizat pentru lucrările respective, respectându-se prezentele instrucțiuni și prescripțiile valabile.

**[ru] Важные указания по подключению/монтажу**

Подключение/монтаж должны выполнять только специалисты, имеющие допуск к выполнению таких работ, при соблюдении требований этой инструкции и действующих норм и правил.

**[sk] Dôležité pokyny týkajúce sa inštalácie/montáže**

Inštaláciu/montáž musí vykonať odborný personál, ktorý má oprávnenie pre výkon týchto prác, pričom musí dodržiavať pokyny uvedené v tomto návode a platné predpisy.

**[sl] Pomembni napotki za namestitvev/montažo**

Inštalacijo/montažo lahko izvede samo pooblaščen strokovnjak ob upoštevanju teh navodil in veljavnih predpisov.

**[sr] Važna uputstva za ugradnju i montažu**

Ovu instalaciju/montažu moraju da obave stručna lica koja su ovlašćena za obavljanje takvih radova u skladu sa ovim uputstvom i važećim propisima.

**[sv] Viktiga anvisningar för installation/montering**

Installationen/monteringen måste utföras av en behörig och tekniskt utbildad person enligt denna anvisning samt gällande föreskrifter.

**[tr] Kurulum/Montaj ile ilgili önemli uyarılar**

Kurulum/montaj, bu çalışmalarını yapmasına müsaade edilen uzman kişiler tarafından işbu kılavuz ve geçerli yönetmelikler dikkate alınarak yapılmalıdır.

**[uk] Важливі вказівки щодо установки/монтажу**

Встановлення/монтаж повинні виконувати фахівці, що допущені до виконання таких робіт, із дотриманням цієї інструкції та діючих приписів.

**[zh] 安装方面的重要提示**

安装和组装工作必须由经过许可的专业人员进行, 同时必须遵守本说明书和现行法规的相关要求

**[ar] ملاحظات هامة للتركيب/التجميع**  
يجب أن يتم التركيب/التجميع من قبل متخصص مصرح له بالعمل، مع مراعاة اللوائح السارية.

**[fa] تذکرات مهم درباره نصب/مونتاژ**  
نصب/مونتاژ باید توسط فردی حرفه ای که مجاز به انجام این کار است، و همچنین با توجه کامل به مقررات مربوطه انجام شود.

**[az] Quraşdırılma**

Quraşdırılma işinin yerinə yetirilməsi səlahiyyətli bir mütəxəssis tərəfindən və müvafiq qaydalara uyğun olaraq aparılmalıdır.

**Ersatzteilliste**  
**Liste des pièces de rechange**

**Lista parti di ricambio**  
**Spare parts list**

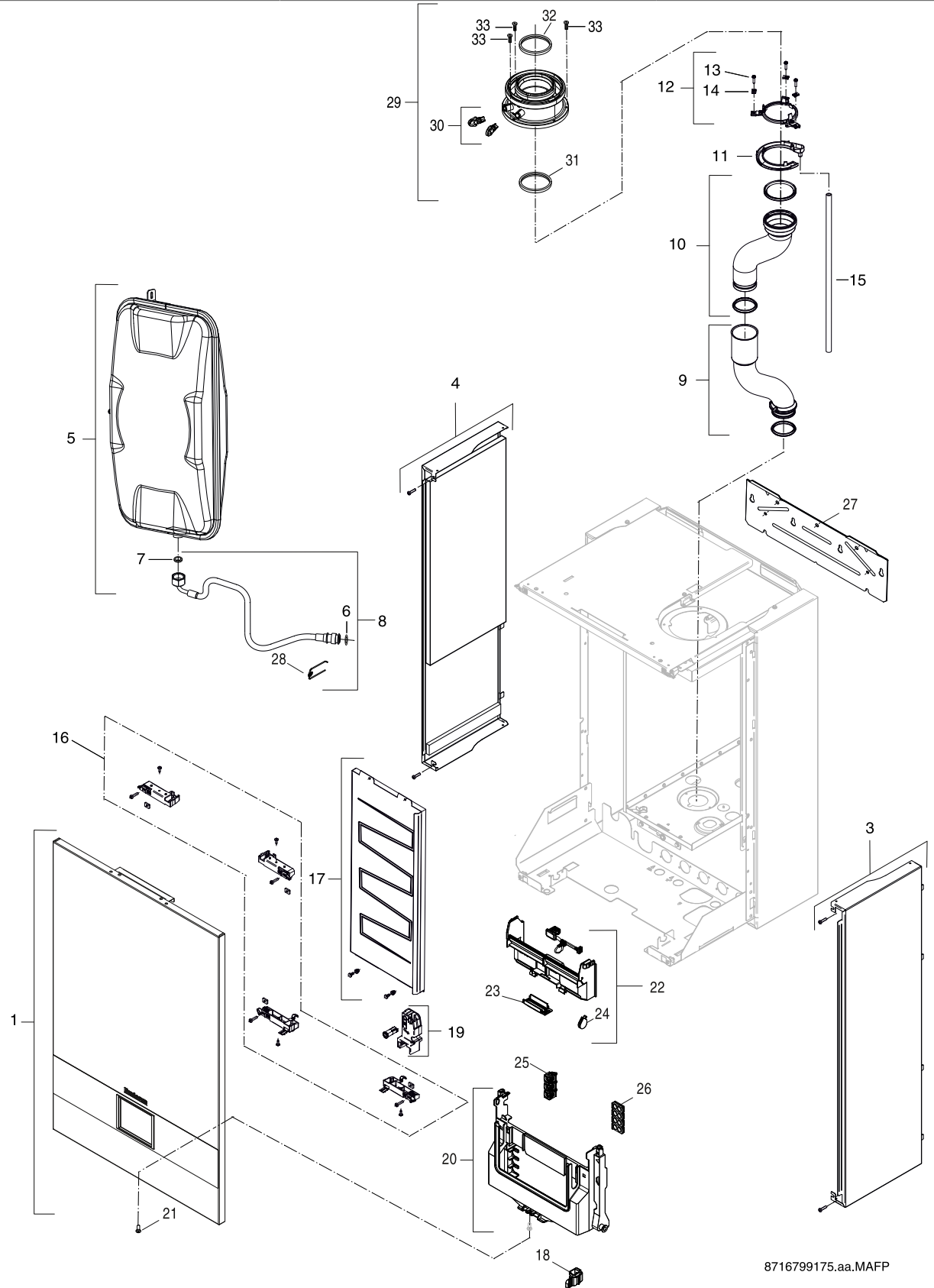

8716799175.aa.MAFP

**1**  
 Blechteile  
 Pièces de tôle  
 Parti di lamiera  
 Sheet metal

**GB172i-24 T50 . . / GB192i-24 T50 . .**  
**Logamax plus**

Pos	Bezeichnung Dénomination Descrizioni Description	Bestell-Nr. Numéro de commande N° d'ordine Ordering no.	7716701563	7716701569	7716701566	7716701567	7716701570	7716701571	7716701574	7716701577	7716701585	7716701586							Bemerkungen Remarques Osservazioni Remarks
1	Vorderwand Buderus	8 716 766 625	■	■	■	■	■	■	■	■	■	■							
1	Vorderwand Buderus weiss Glas FR	8 737 714 065			■		■												
3	Seitenwand (SQ RechtsWeiss+Schaumstoff)	8 716 766 643	■	■	■	■	■	■	■	■	■	■							
3	Seitenwand (SQ RechtsSilber+Schaumstoff)	8 716 766 645			■		■												
4	Seitenwand (links Weiß+Schaumstoff)	8 716 766 644	■	■	■	■	■	■	■	■	■	■							
4	Seitenwand (SQ RechtsSilber+Schaumstoff)	8 716 766 646			■		■												
5	Ausdehnungsgefäß	8 715 407 328 0	■	■	■	■	■	■	■	■	■	■							
6	O-Ring 13,87x3,53 L (10x)	8 716 107 439 0	■	■	■	■	■	■	■	■	■	■							
7	Dichtung 18,6x13,5x1,5 (10x)	8 710 103 045 0	■	■	■	■	■	■	■	■	■	■							
8	Rohr Wellrohr	8 716 764 366 0	■	■	■	■	■	■	■	■	■	■							
9	Unterer Abgasaustritt	8 716 766 504	■	■	■	■	■	■	■	■	■	■							
10	Oberer Abgasaustritt	8 716 766 505	■	■	■	■	■	■	■	■	■	■							
11	Befestigungsblech Aufhängung	8 718 650 036 0	■	■	■	■	■	■	■	■	■	■							
12	Halter Abgasrohr	8 718 682 454 0	■	■	■	■	■	■	■	■	■	■							
13	Schraube No.10x20 Hex Flansch (3x)	8 716 109 363 0	■	■	■	■	■	■	■	■	■	■							
14	Mutter 4,8mm (10x)	8 710 609 015 0	■	■	■	■	■	■	■	■	■	■							
15	Silikon Schlauch	8 716 766 624	■	■	■	■	■	■	■	■	■	■							
16	Schalltafelarretierung	8 716 766 507	■	■	■	■	■	■	■	■	■	■							
17	Abdeckung Luftkasten	8 716 766 508	■	■	■	■	■	■	■	■	■	■							
18	Klipp Steuergerätaufnahme oben (2x)	8 737 709 145	■	■	■	■	■	■	■	■	■	■							
19	Arretierungsbedienfeld	8 716 766 524	■	■	■	■	■	■	■	■	■	■							
20	Halter Steuergerät	8 737 709 147	■	■	■	■	■	■	■	■	■	■							
21	Schraube	2 910 642 162 0	■	■	■	■	■	■	■	■	■	■							
22	Abdeckung (Zugang Installateur)	8 737 709 196	■	■	■	■	■	■	■	■	■	■							
23	Abdeckung (Ip PluX)	8 737 709 148	■	■	■	■	■	■	■	■	■	■							
24	Verriegelung (PluX)	8 737 709 149	■	■	■	■	■	■	■	■	■	■							
25	Zugentlastung	8 712 201 007 0	■	■	■	■	■	■	■	■	■	■							
26	Kabeldurchführung 2-polig	8 737 704 495 0	■	■	■	■	■	■	■	■	■	■							
27	Strebe	8 716 766 628	■	■	■	■	■	■	■	■	■	■							
28	Haltefeder 18mm (10x)	8 718 684 699 0	■	■	■	■	■	■	■	■	■	■							
29	KAS konzentrisch Ø80/125	7 738 112 714	■		■	■	■	■	■	■	■	■							
30	Stopfen	8 716 763 266 0	■		■	■	■	■	■	■	■	■							
31	Dichtung D80	8 718 220 336 0	■		■	■	■	■	■	■	■	■							
32	Lippendichtung DN125	8 716 763 264 0	■		■	■	■	■	■	■	■	■							
33	Schraube 4,8x30 (3x)	8 713 403 039 0	■		■	■	■	■	■	■	■	■							

**GB172i-24 T50 . . / GB192i-24 T50 . .**  
**Logamax plus**

Blechteile  
Pièces de tôle  
Parti di lamiera  
Sheet metal

**1**

**Ersatzteilliste**  
**Liste des pièces de rechange**

**Lista parti di ricambio**  
**Spare parts list**

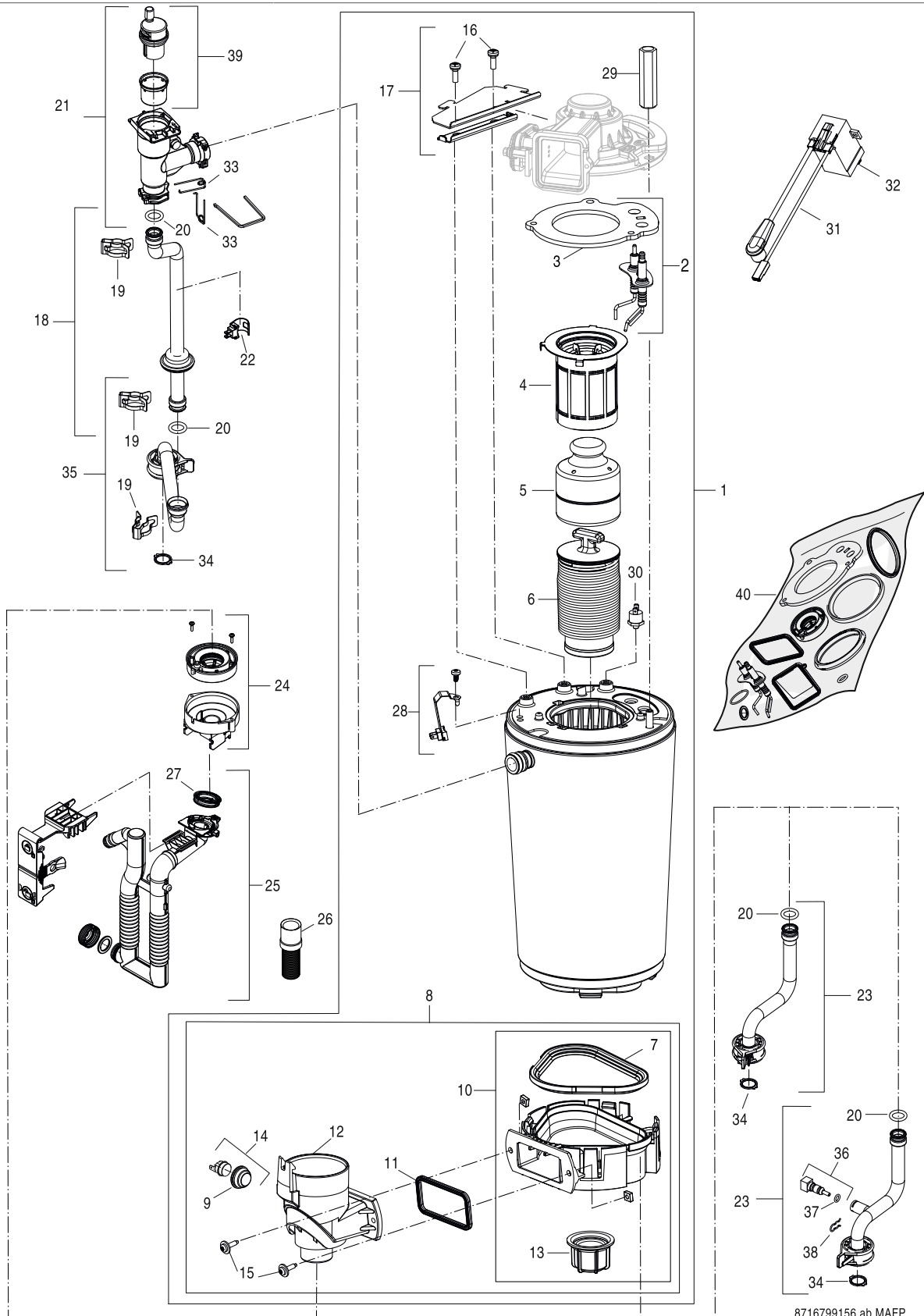

8716799156.ab.MAFP

**2**

Brenner/Wärmeübertrager  
Brûleur/corps de chauffe  
Bruciatore/Blocco lamellare  
Burner/Heat exchanger

**GB172i-24 T50 .. / GB192i-24 T50 ..**  
**Logamax plus**

Pos	Bezeichnung Dénomination Descrizioni Description	Bestell-Nr. Numéro de commande N° d'ordine Ordering no.	7716701553	7716701559	7716701566	7716701567	7716701570	7716701571	7716701574	7716701577	7716701585	7716701586							Bemerkungen Remarques Osservazioni Remarks
1	Wärmetauscher 30kW	8 716 766 544	■	■	■	■	■	■	■	■	■	■							
2	Elektroden-Set	8 737 903 536 0	■	■	■	■	■	■	■	■	■	■							
3	Dichtung Brenner	8 718 650 789 0	■	■	■	■	■	■	■	■	■	■							
4	Brenner 30 kW	8 718 650 984 0	■	■	■	■	■	■	■	■	■	■							
5	Verdrängungskörper	8 715 405 197 0	■	■	■	■	■	■	■	■	■	■							
6	Körper unten	8 737 602 342	■	■	■	■	■	■	■	■	■	■							
7	Dichtung	8 718 651 071 0	■	■	■	■	■	■	■	■	■	■							
8	Ausgestatteter Ablauftrichter	8 716 766 513	■	■	■	■	■	■	■	■	■	■							
9	Tülle	8 737 902 638 0	■	■	■	■	■	■	■	■	■	■							
10	Ablauftrichter	8 716 766 514	■	■	■	■	■	■	■	■	■	■							
11	Dichtung Dichtgummi	8 716 764 187 0	■	■	■	■	■	■	■	■	■	■							
12	AZ Abgassammelkanal	8 716 764 363 0	■	■	■	■	■	■	■	■	■	■							
13	Mutter	8 713 301 114 0	■	■	■	■	■	■	■	■	■	■							
14	Temperaturbegrenzer	8 710 506 267 0	■	■	■	■	■	■	■	■	■	■							
15	Schraube	8 716 764 184 0	■	■	■	■	■	■	■	■	■	■							
16	Schraube M6x18 (10x)	8 737 602 143	■	■	■	■	■	■	■	■	■	■							
17	Unterstützung Wärmetauscher	8 716 766 510	■	■	■	■	■	■	■	■	■	■							
18	Vorlaufrohr C6 (Oben)	8 716 766 541	■	■	■	■	■	■	■	■	■	■							
19	Klammer (10x)	8 711 200 024 0	■	■	■	■	■	■	■	■	■	■							
20	O-Ring 17x4 (10x)	8 716 771 154 0	■	■	■	■	■	■	■	■	■	■							
21	Entlüfter/Wärmetauscher-Krümmen-Baugrupp	8 716 766 617	■	■	■	■	■	■	■	■	■	■							
22	Temperaturfühler 18mm	8 718 688 801 0	■	■	■	■	■	■	■	■	■	■							
23	Rücklaufrohr C6	8 716 766 543			■														
23	Rücklaufrohr C6 COIL	8 716 766 618	■	■		■			■	■	■	■							
24	Verbindung Zum Siphon	8 716 766 516	■	■	■	■	■	■	■	■	■	■							
25	Siphon	8 737 602 314	■	■	■	■	■	■	■	■	■	■							
26	Schlauch Kondensatschlauch	8 737 712 737	■	■	■	■	■	■	■	■	■	■							
27	Dichtung Siphon	8 737 602 313	■	■	■	■	■	■	■	■	■	■							
28	Temperaturfühler NTC	8 737 602 343	■	■	■	■	■	■	■	■	■	■							
29	Mutter M8	8 716 766 517	■	■	■	■	■	■	■	■	■	■							
30	Temperaturbegrenzer	8 737 903 399 0	■	■	■	■	■	■	■	■	■	■							
31	Zündkabel	8 737 902 999 0	■	■	■	■	■	■	■	■	■	■							
32	Zündtrafo	7 736 700 599	■	■	■	■	■	■	■	■	■	■							
33	Haltefeder 18mm (10x)	8 718 684 699 0	■	■	■	■	■	■	■	■	■	■							
34	Dichtung 18,5x24,3 (10x)	8 716 771 259 0	■	■	■	■	■	■	■	■	■	■							
35	Vorlaufrohr C6 (Unter)	8 716 766 620			■														
36	Temperaturfühler	8 714 500 055 0	■	■	■	■	■	■	■	■	■	■							
37	O-Ring 8x2 (10x)	8 710 205 076 0	■	■	■	■	■	■	■	■	■	■							
38	Haltefeder (10x)	8 711 200 015 0	■	■	■	■	■	■	■	■	■	■							
39	Entlüfter	8 716 766 653	■	■	■	■	■	■	■	■	■	■							
40	Service-Kit	8 716 766 654	■	■	■	■	■	■	■	■	■	■							

**GB172i-24 T50 . . / GB192i-24 T50 . .**  
**Logamax plus**

Brenner/Wärmeübertrager  
Brûleur/corps de chauffe  
Bruciatore/Blocco lamellare  
Burner/Heat exchanger

**2**

**Ersatzteilliste**  
**Liste des pièces de rechange**

**Lista parti di ricambio**  
**Spare parts list**

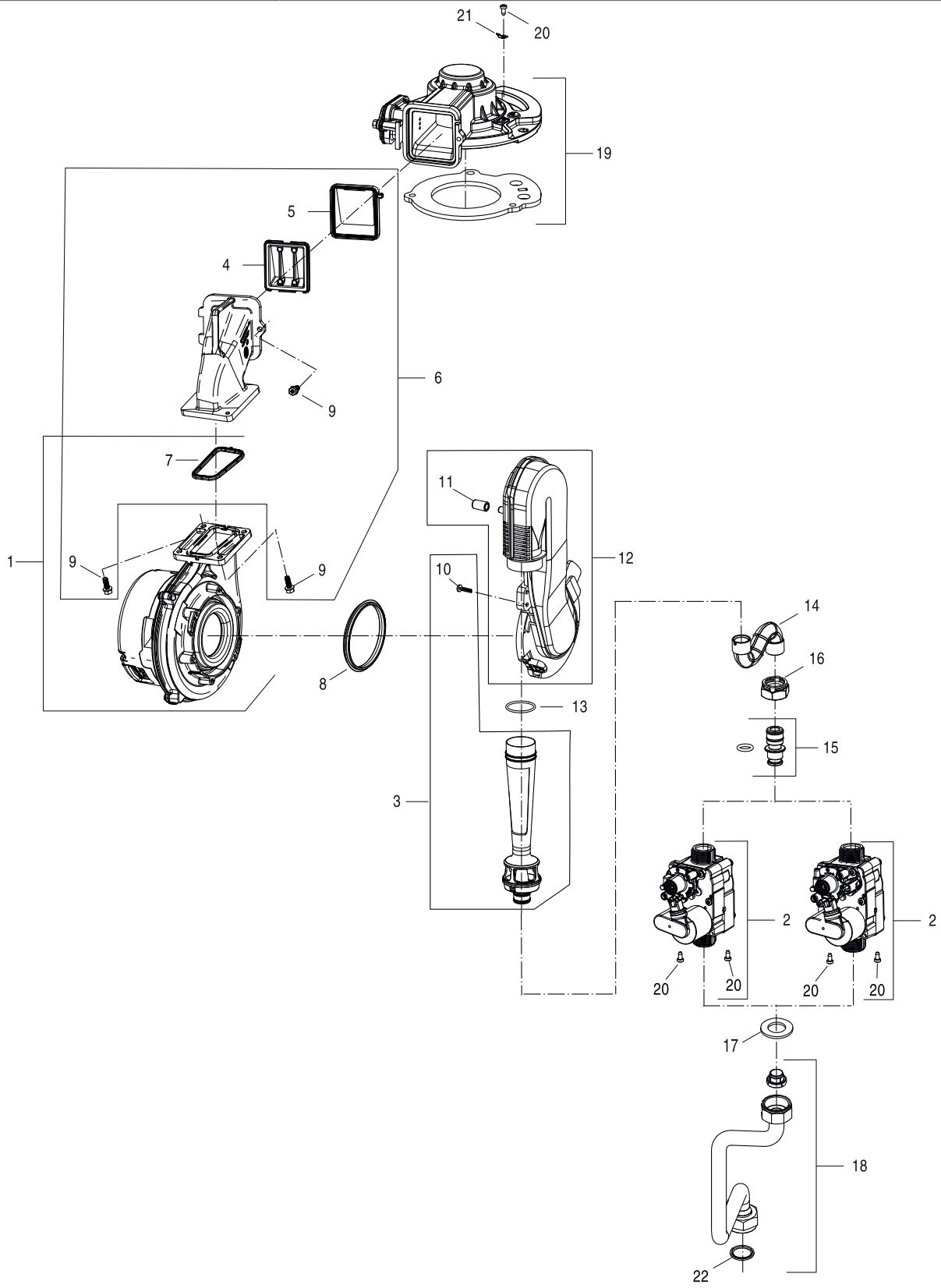

8716799172.ab.MAFP

**3**  
 Gasarmatur  
 Bloc gaz  
 Gruppo gas  
 Gas valve

**GB172i-24 T50 . . / GB192i-24 T50 . .**  
**Logamax plus**



Pos	Bezeichnung Dénomination Descrizioni Description	Bestell-Nr. Numéro de commande N° d'ordine Ordering no.	7716701553	7716701559	7716701566	7716701567	7716701570	7716701571	7716701574	7716701577	7716701585	7716701586							Bemerkungen Remarques Osservazioni Remarks
1	Gebläse	8 718 651 784 0	■	■	■	■	■	■	■	■	■	■							
2	Gasarmatur	8 718 651 802 0		■						■	■	■							
2	Gasarmatur	8 737 604 361	■		■	■	■	■											
3	Venturi 30 kW G20/G31	8 718 650 605 0		■			■	■	■	■	■	■							
3	Venturi 30 kW G25/GZ35A	8 718 650 947 0	■		■	■													
4	Klappenschutz	8 716 117 051	■	■	■	■	■	■	■	■	■	■							
5	Rückströmsicherung	8 716 117 050	■	■	■	■	■	■	■	■	■	■							
6	Gebläse Kanal	8 716 766 518	■	■	■	■	■	■	■	■	■	■							
7	Dichtung (Gebläse)	8 718 660 208 0	■	■	■	■	■	■	■	■	■	■							
8	Dichtung	7 746 001 88A 0	■	■	■	■	■	■	■	■	■	■							
9	Schraube M5x15 (3x)	8 718 651 785 0	■	■	■	■	■	■	■	■	■	■							
10	Schraube 4x15 (10x)	8 737 700 103 0	■	■	■	■	■	■	■	■	■	■							
11	Kappe (1x)	8 737 902 864 0	■	■	■	■	■	■	■	■	■	■							
12	Luftansaugrohr	8 718 650 806 0	■	■	■	■	■	■	■	■	■	■							
13	O-Ring NBR 29x2 (10x)	8 718 662 626 0	■	■	■	■	■	■	■	■	■	■							
14	Gasrohr	8 718 650 473 0	■	■	■	■	■	■	■	■	■	■							
15	Gasdüse 30 kW G31	8 718 651 017 0					■	■											
15	Gasdüse 30kW G20	8 718 651 018 0		■						■	■	■							
15	Gasdüse 30 kW G20 / G25	8 737 603 467	■		■	■													
16	Mutter	8 716 106 683 0	■	■	■	■	■	■	■	■	■	■							
17	Dichtung Gasarmatur 41x3 (10x)	8 718 668 449 0	■	■	■	■	■	■	■	■	■	■							
18	Gasrohr	8 716 766 519	■	■	■	■	■	■	■	■	■	■							
19	Kanal Gas-Luft-Gemisch	8 718 649 668 0	■	■	■	■	■	■	■	■	■	■							
20	Schraube M4x8 (10x)	8 718 644 553 0	■	■	■	■	■	■	■	■	■	■							
21	Steckeranschlusssockel 6.3	8 718 652 196 0	■	■	■	■	■	■	■	■	■	■							
22	Dichtung 18,3x24,3 (10x)	8 710 103 161 0	■	■	■	■	■	■	■	■	■	■							

**GB172i-24 T50 . . / GB192i-24 T50 . .**  
**Logamax plus**

Gasarmatur  
Bloc gaz  
Gruppo gas  
Gas valve

**3**

**Ersatzteilliste**  
**Liste des pièces de rechange**

**Lista parti di ricambio**  
**Spare parts list**

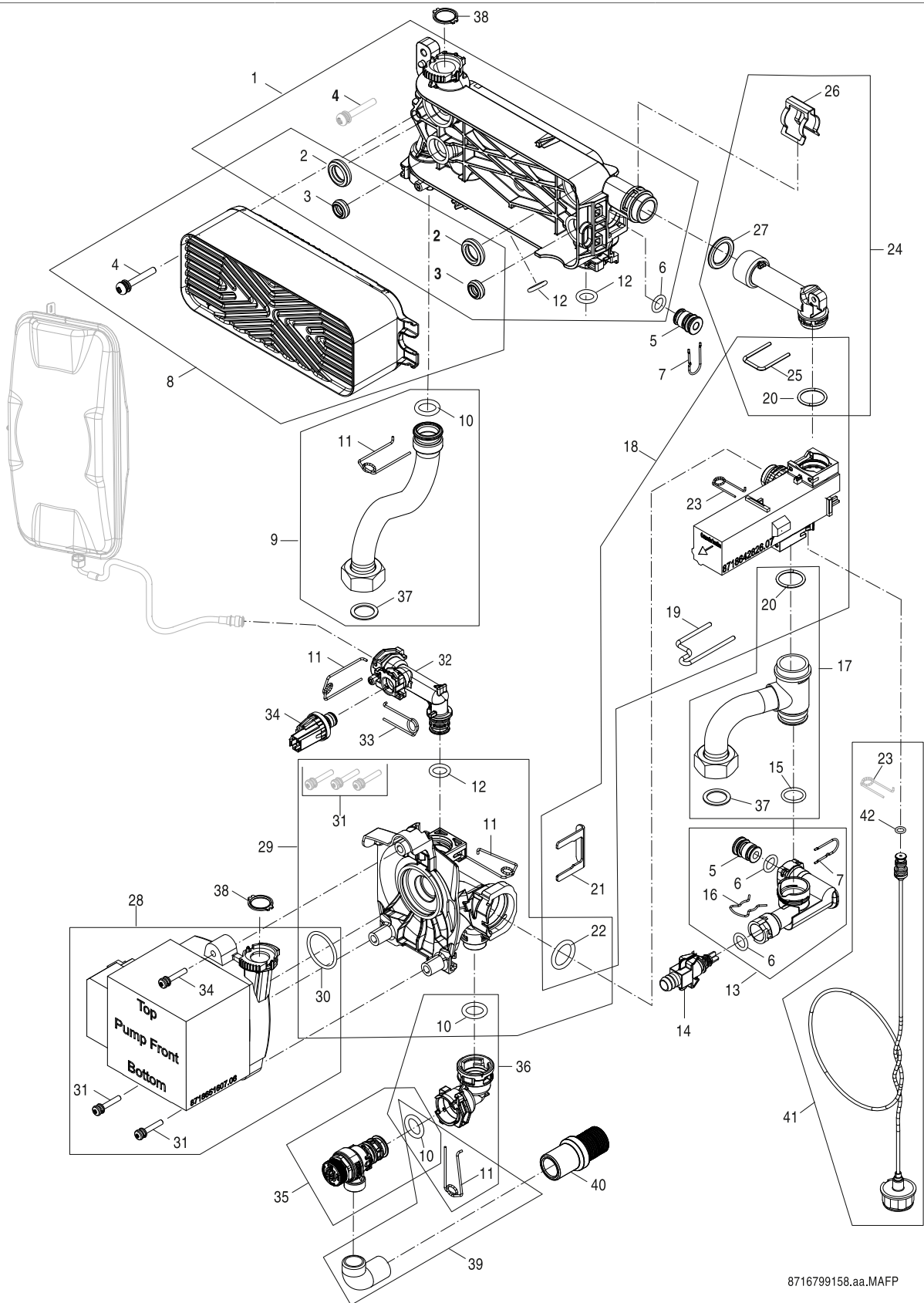

8716799158.aa.MAFP

**4A**  
 42L Hydraulik  
 Hydraulique ballon 42L  
 Allacciamento 42L  
 Hydraulics tank 42L

**GB172i-24 T50 . . / GB192i-24 T50 . .**  
**Logamax plus**



**Ersatzteilliste**  
**Liste des pièces de rechange**

**Lista parti di ricambio**  
**Spare parts list**

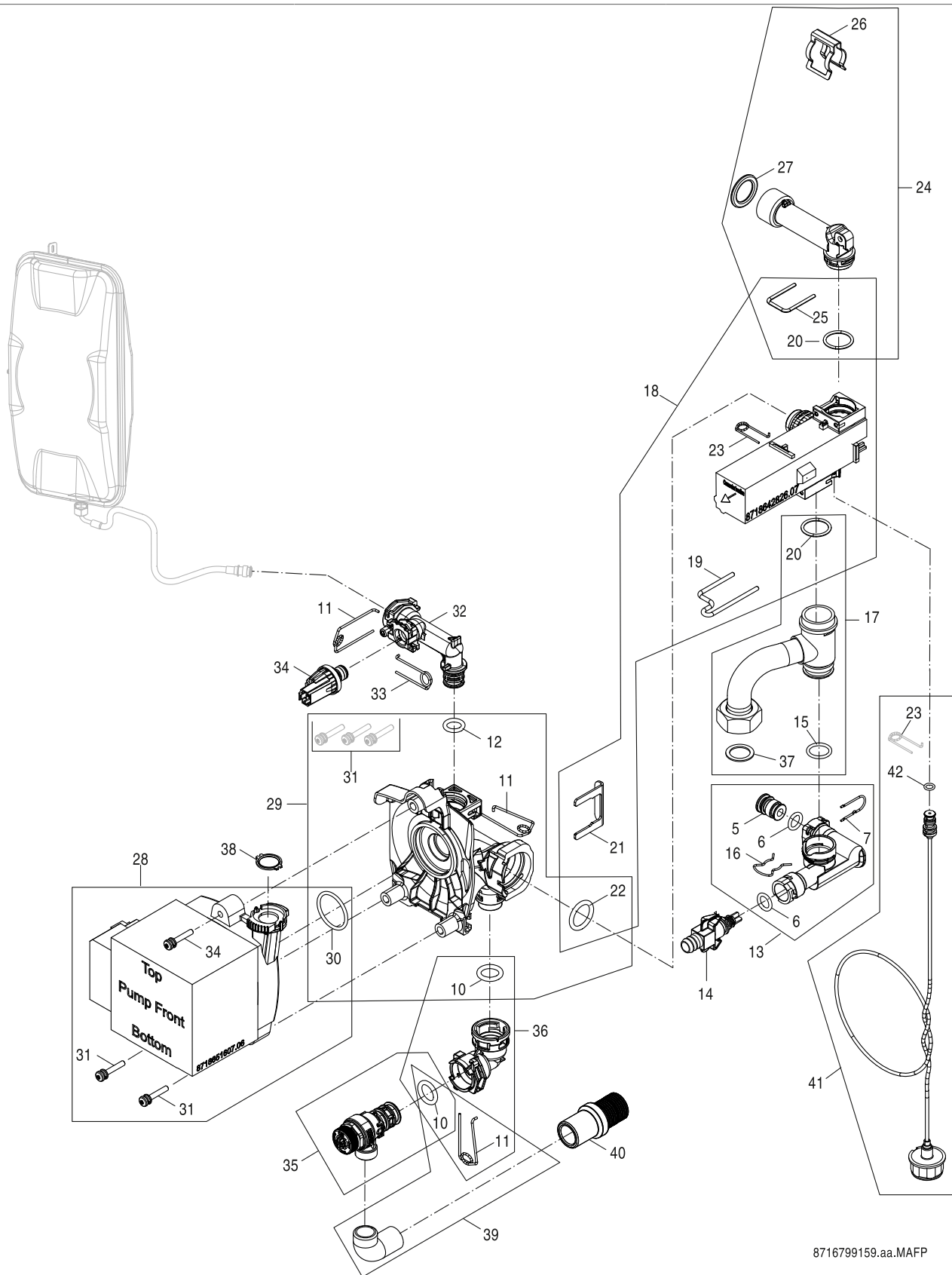

**4B**

48M Hydraulik  
 Hydraulique ballon 48L  
 Allacciamento 48L  
 Hydraulics tank 48L

**GB172i-24 T50 . . / GB192i-24 T50 . .**  
**Logamax plus**

Pos	Bezeichnung Dénomination Descrizioni Description	Bestell-Nr. Numéro de commande N° d'ordine Ordering no.	7716701553	7716701559	7716701566	7716701567	7716701570	7716701571	7716701574	7716701577	7716701585	7716701586							Bemerkungen Remarques Osservazioni Remarks
5	Stopfen (5x)	8 718 222 478 0	■	■	■	■	■	■	■	■	■	■							
6	O-Ring 12,5x3 WRAS / KTW (1x)	8 716 106 748 0	■	■	■	■	■	■	■	■	■	■							
7	Haltefeder 13mm	8 716 106 549 0	■	■	■	■	■	■	■	■	■	■							
10	O-Ring 17x4 (10x)	8 716 771 154 0	■	■	■	■	■	■	■	■	■	■							
11	Haltefeder 18mm (10x)	8 718 684 699 0	■	■	■	■	■	■	■	■	■	■							
12	O-Ring 13,87x3,53 L (10x)	8 716 107 439 0	■	■	■	■	■	■	■	■	■	■							
13	Rücklaufrohr	8 737 602 352	■	■	■	■	■	■	■	■	■	■							
14	Füllhahn	8 716 771 432 0	■	■	■	■	■	■	■	■	■	■							
15	O-Ring 18,7x2,7 (10x)	8 718 640 414 0	■	■	■	■	■	■	■	■	■	■							
16	Haltefeder (10x)	8 711 200 016 0	■	■	■	■	■	■	■	■	■	■							
17	Zusammenbau Rücklauf Rohr	8 737 711 825	■	■	■	■	■	■	■	■	■	■							
18	3-Wege-Ventil	8 737 602 350	■	■	■	■	■	■	■	■	■	■							
19	Haltefeder (10x)	8 737 602 355	■	■	■	■	■	■	■	■	■	■							
20	O-Ring 23,47x2,62 (10x)	8 737 602 349	■	■	■	■	■	■	■	■	■	■							
21	Sicherungsklammer (10x)	8 718 681 920 0	■	■	■	■	■	■	■	■	■	■							
22	O-Ring 23x4 (10x)	8 716 771 353 0	■	■	■	■	■	■	■	■	■	■							
23	Haltefeder 10mm (10x)	8 716 771 167 0	■	■	■	■	■	■	■	■	■	■							
24	Verbindungsrohr	8 737 602 348	■	■	■	■	■	■	■	■	■	■							
25	Haltefeder (10x)	8 737 602 356	■	■	■	■	■	■	■	■	■	■							
26	Klammer (10x)	8 716 113 918 0	■	■	■	■	■	■	■	■	■	■							
27	O-Ring 20,22x3,53 EPDM (10x)	8 718 685 490 0	■	■	■	■	■	■	■	■	■	■							
28	Pumpe ErP SpE HU2-10	8 737 602 344	■	■	■	■	■	■	■	■	■	■							
29	Rohr	8 737 602 345	■	■	■	■	■	■	■	■	■	■							
30	O-Ring 34x3 (10x)	8 737 602 346	■	■	■	■	■	■	■	■	■	■							
31	Schraube M5x30 + Unterlegscheibe	8 716 106 452 0	■	■	■	■	■	■	■	■	■	■							
32	Anschlussstück (Außdehnungsgefäß)	8 718 648 973 0	■	■	■	■	■	■	■	■	■	■							
33	Federverriegelung 10mm	8 718 663 229 0	■	■	■	■	■	■	■	■	■	■							
34	Druckfühler	8 718 651 042 0	■	■	■	■	■	■	■	■	■	■							
35	Sicherheitsventil	8 718 643 989 0	■	■	■	■	■	■	■	■	■	■							
36	Verbindungsrohr (Sicherheitsventil)	8 737 602 347	■	■	■	■	■	■	■	■	■	■							
37	Dichtung 23,9x17,2x1,5 (10x)	8 710 103 043 0	■	■	■	■	■	■	■	■	■	■							
38	Dichtung 18,5x24,3 (10x)	8 716 771 259 0	■	■	■	■	■	■	■	■	■	■							
39	Bogen	8 718 642 979 0	■	■	■	■	■	■	■	■	■	■							
40	Schlauch	8 718 220 106 0	■	■	■	■	■	■	■	■	■	■							
41	Manometer	8 718 224 344 0	■	■	■	■	■	■	■	■	■	■							
42	O-Ring 2,62x6,02 WRAS / KTW (10x)	8 716 140 810 0	■	■	■	■	■	■	■	■	■	■							

**GB172i-24 T50 . . / GB192i-24 T50 . .**  
**Logamax plus**

48M Hydraulik  
Hydraulique ballon 48L  
Allacciamento 48L  
Hydraulics tank 48L

**4B**

**Ersatzteilliste**  
**Liste des pièces de rechange**

**Lista parti di ricambio**  
**Spare parts list**

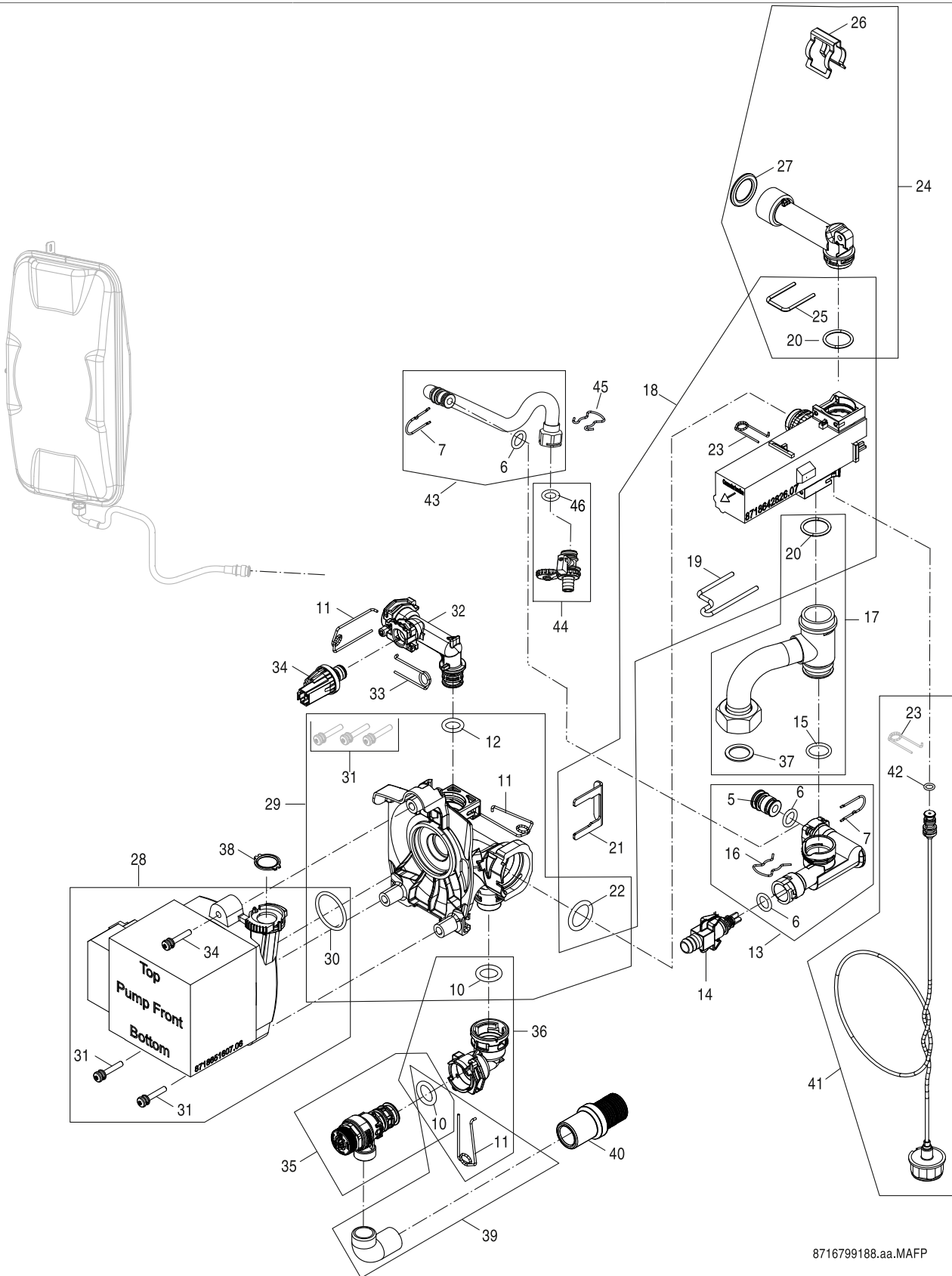

8716799188.aa.MAFP

**4C**

48M Hydraulik  
 Hydraulique ballon 48L  
 Allacciamento 48L  
 Hydraulics tank 48L

**GB172i-24 T50 . . / GB192i-24 T50 . .**  
**Logamax plus**

Pos	Bezeichnung Dénomination Descrizioni Description	Bestell-Nr. Numéro de commande N° d'ordine Ordering no.	7716701553	7716701559	7716701566	7716701567	7716701570	7716701571	7716701574	7716701577	7716701585	7716701586							Bemerkungen Remarques Osservazioni Remarks
5	Stopfen (5x)	8 718 222 478 0	■																
6	O-Ring 12,5x3 WRAS / KTW (1x)	8 716 106 748 0	■																
7	Haltefeder 13mm	8 716 106 549 0	■																
10	O-Ring 17x4 (10x)	8 716 771 154 0	■																
11	Haltefeder 18mm (10x)	8 718 684 699 0	■																
12	O-Ring 13,87x3,53 L (10x)	8 716 107 439 0	■																
13	Rücklaufrohr	8 737 602 352	■																
14	Füllhahn	8 716 771 432 0	■																
15	O-Ring 18,7x2,7 (10x)	8 718 640 414 0	■																
16	Haltefeder (10x)	8 711 200 016 0	■																
17	Zusammenbau Rücklauf Rohr	8 737 711 825	■																
18	3-Wege-Ventil	8 737 602 350	■																
19	Haltefeder (10x)	8 737 602 355	■																
20	O-Ring 23,47x2,62 (10x)	8 737 602 349	■																
21	Sicherungsklammer (10x)	8 718 681 920 0	■																
22	O-Ring 23x4 (10x)	8 716 771 353 0	■																
23	Haltefeder 10mm (10x)	8 716 771 167 0	■																
24	Verbindungsrohr	8 737 602 348	■																
25	Haltefeder (10x)	8 737 602 356	■																
26	Klammer (10x)	8 716 113 918 0	■																
27	O-Ring 20,22x3,53 EPDM (10x)	8 718 685 490 0	■																
28	Pumpe ErP SpE HU2-10	8 737 602 344	■																
29	Rohr	8 737 602 345	■																
30	O-Ring 34x3 (10x)	8 737 602 346	■																
31	Schraube M5x30 + Unterlegscheibe	8 716 106 452 0	■																
32	Anschlussstück (Außdehnungsgefäß)	8 718 648 973 0	■																
33	Federverriegelung 10mm	8 718 663 229 0	■																
34	Druckfühler	8 718 651 042 0	■																
35	Sicherheitsventil	8 718 643 989 0	■																
36	Verbindungsrohr (Sicherheitsventil)	8 737 602 347	■																
37	Dichtung 23,9x17,2x1,5 (10x)	8 710 103 043 0	■																
38	Dichtung 18,5x24,3 (10x)	8 716 771 259 0	■																
39	Bogen	8 718 642 979 0	■																
40	Schlauch	8 718 220 106 0	■																
41	Manometer	8 718 224 344 0	■																
42	O-Ring 2,62x6,02 WRAS / KTW (10x)	8 716 140 810 0	■																
43	Füll- und Entleerungshahn	8 716 766 996	■																
44	Füll- und Entleerungshahn schwarz	7 101 556	■																
45	Bügel D15	8 716 766 536	■																
46	O-Ring 15,88x2,62mm (10x)	8 738 725 455	■																

**GB172i-24 T50 . . / GB192i-24 T50 . .**  
**Logamax plus**

48M Hydraulik  
Hydraulique ballon 48L  
Allacciamento 48L  
Hydraulics tank 48L

**4C**

**Ersatzteilliste**  
**Liste des pièces de rechange**

**Lista parti di ricambio**  
**Spare parts list**

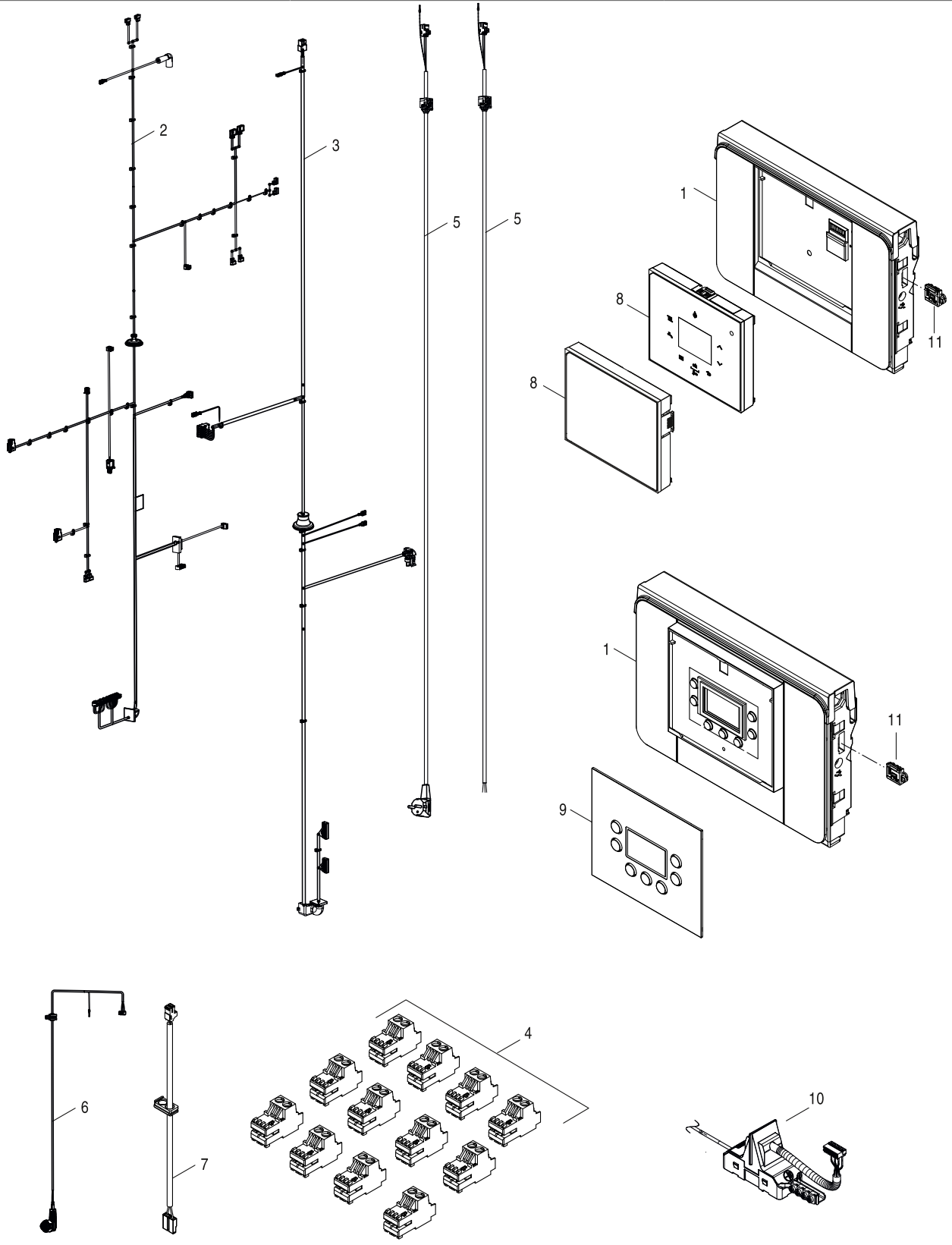

8716799184.aa.MAFP

**5** Schaltkasten  
 Tableau électrique  
 Quadro comandi  
 Control box

**GB172i-24 T50 . . / GB192i-24 T50 . .**  
**Logamax plus**





**Ersatzteilliste**  
**Liste des pièces de rechange**

**Lista parti di ricambio**  
**Spare parts list**

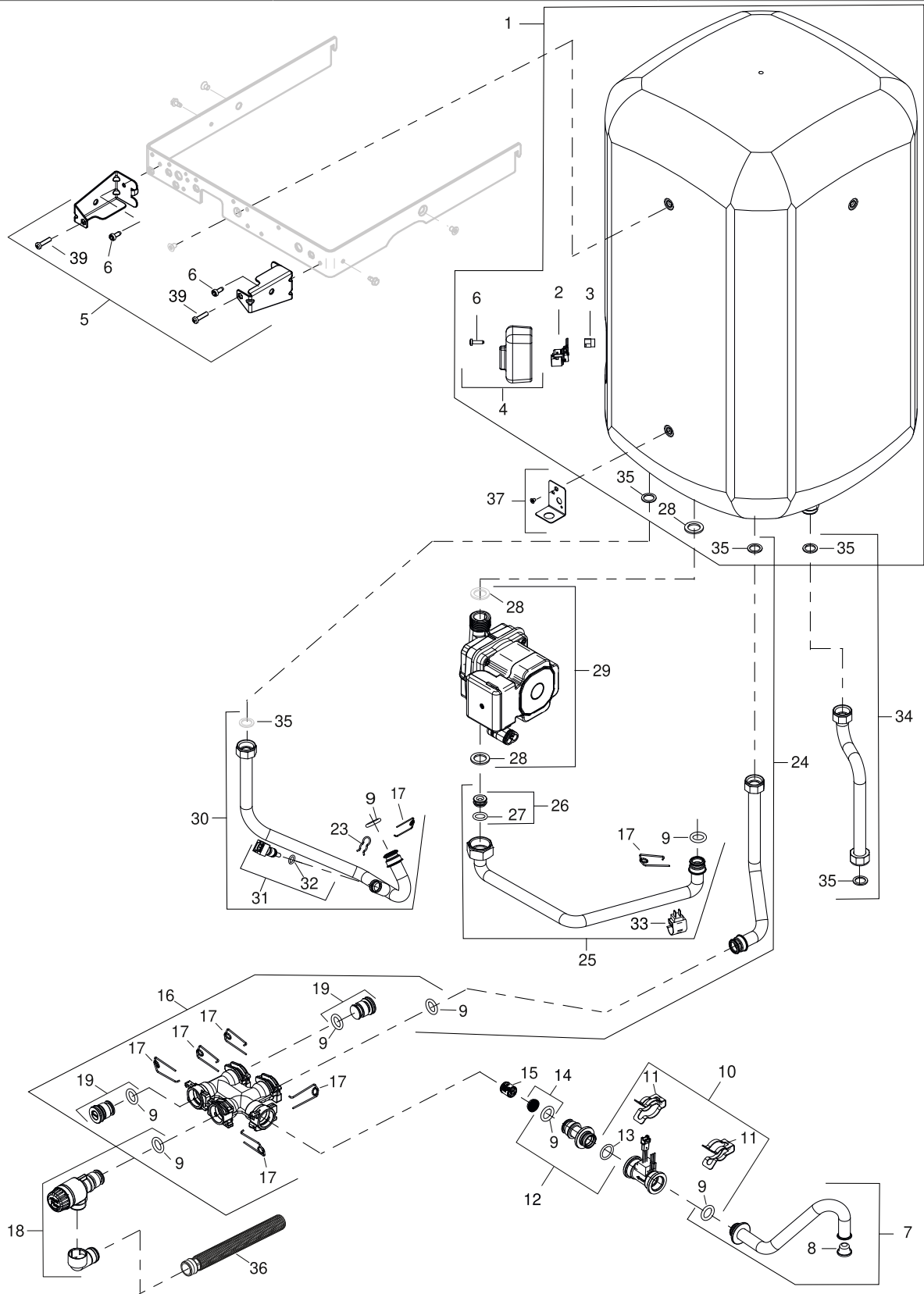

8716799183.ac.MAFP

**6A**

Speicherbehälter 42 L  
 Ballon 42 L  
 Bollitore 42 L  
 Storage tank 42 L w/o expansion vessel

**GB172i-24 T50 .. / GB192i-24 T50 ..**  
**Logamax plus**



**Ersatzteilliste**  
**Liste des pièces de rechange**

**Lista parti di ricambio**  
**Spare parts list**

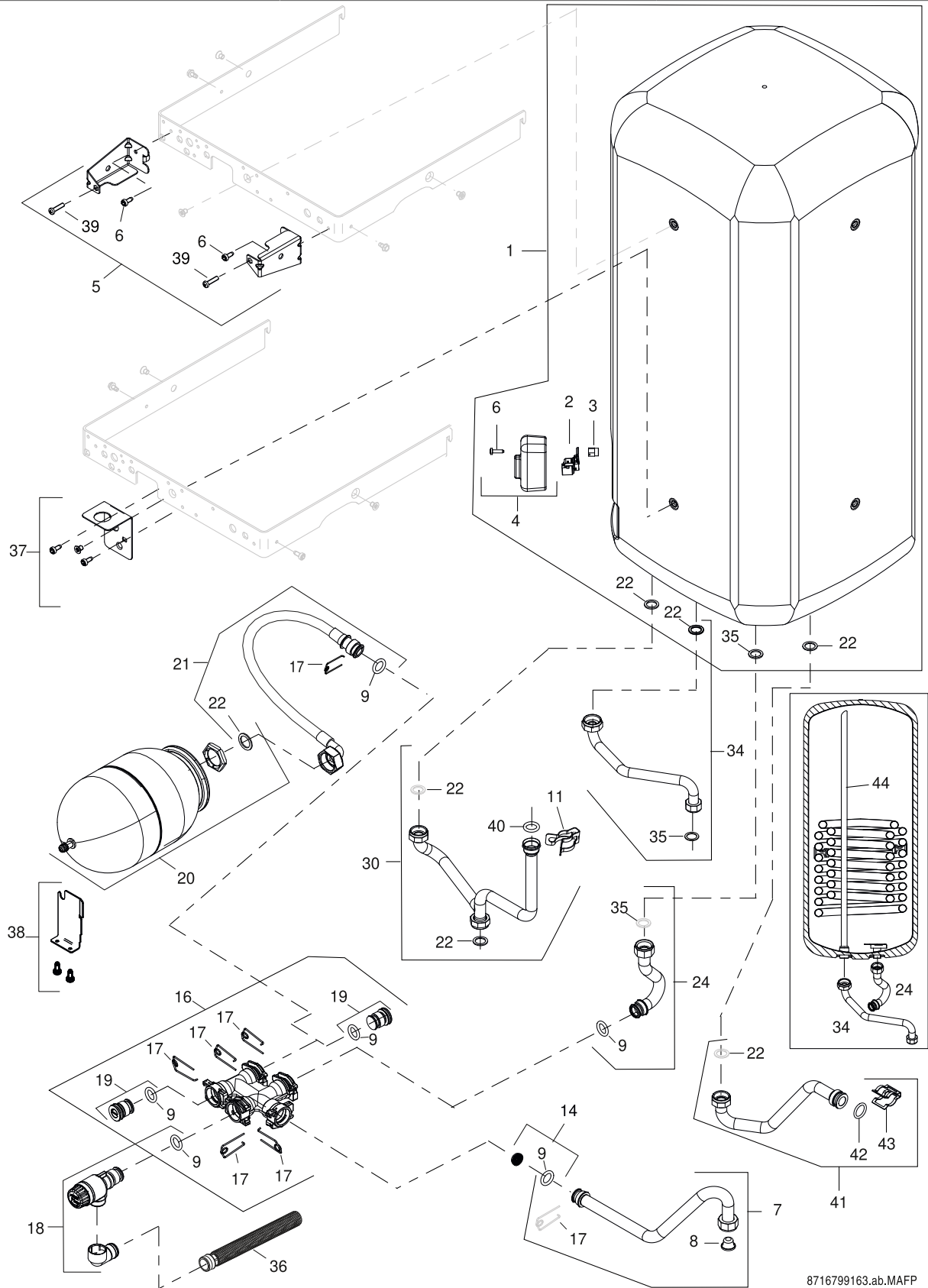

8716799163.ab.MAFP

**6B**  
 Speicherbehälter 48 L  
 Ballon 48 L  
 Bollitore 48 L  
 Storage tank 48 L

**GB172i-24 T50 .. / GB192i-24 T50 ..**  
**Logamax plus**



**Ersatzteilliste**  
**Liste des pièces de rechange**

**Lista parti di ricambio**  
**Spare parts list**

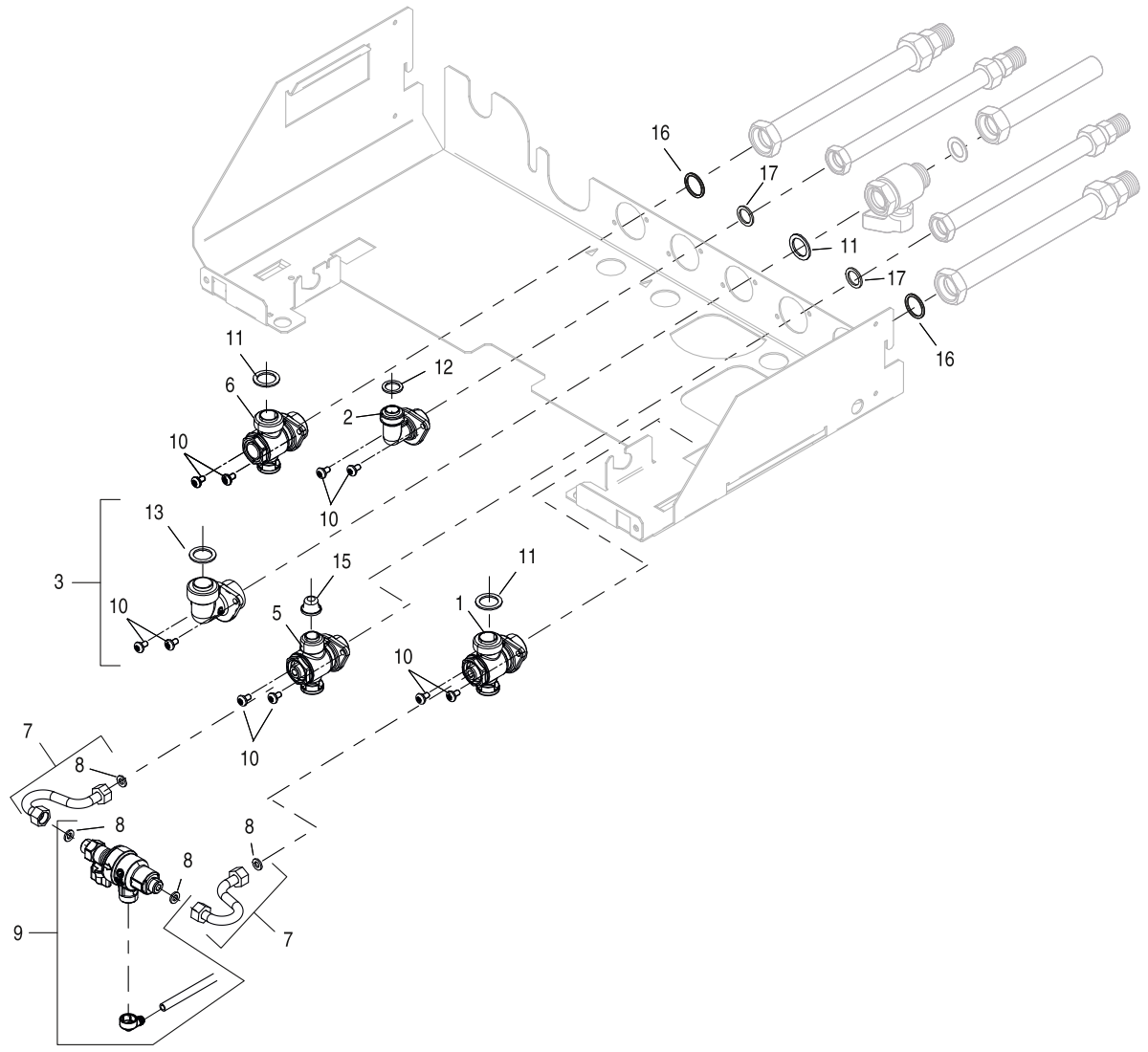

8716799176.ab.MAFP

**7A**  
 Absperrventil  
 Raccordement vannes  
 Collegamento valvola d'intercettazione  
 Connection shut-off valves

**GB172i-24 T50 . . / GB192i-24 T50 . .**  
**Logamax plus**

Pos	Bezeichnung Dénomination Descrizioni Description	Bestell-Nr. Numéro de commande N° d'ordine Ordering no.	7716701553	7716701559	7716701566	7716701567	7716701570	7716701571	7716701574	7716701577	7716701585	7716701586								Bemerkungen Remarques Osservazioni Remarks
1	Ventil	8 716 156 759 0	■																	
2	Anschlussstück	8 713 305 610 0	■																	
3	Gasbogen	8 716 766 642	■																	
5	Ventil	8 716 771 286 0	■																	
6	Wasserarmatur 3/4"	8 716 771 633 0	■																	
7	Rohr Disconnecteur	8 716 762 262 0	■																	
8	Dichtung 6x11x1,5 (10x)	8 710 103 123 0	■																	
9	Fülleinrichtung	8 716 770 004 0	■																	
10	Schraube (10x)	8 718 642 109 0	■																	
11	Dichtung 23,9x17,2x1,5 (10x)	8 710 103 043 0	■																	
12	Dichtung 18,6x13,5x1,5 (10x)	8 710 103 045 0	■																	
13	Dichtung 18,3x24,3 (10x)	8 710 103 161 0	■																	
15	Filter (10x)	8 716 766 126	■																	
16	Dichtscheibe 3/4" (10x)	8 710 103 117 0	■																	
17	Dichtscheibe 1/2" (10x)	8 710 103 116 0	■																	

**GB172i-24 T50 . . / GB192i-24 T50 . .**  
**Logamax plus**

Absperrventil  
Raccordement vannes  
Collegamento valvola d'intercettazione  
Connection shut-off valves

**7A**

**Ersatzteilliste**  
**Liste des pièces de rechange**

**Lista parti di ricambio**  
**Spare parts list**

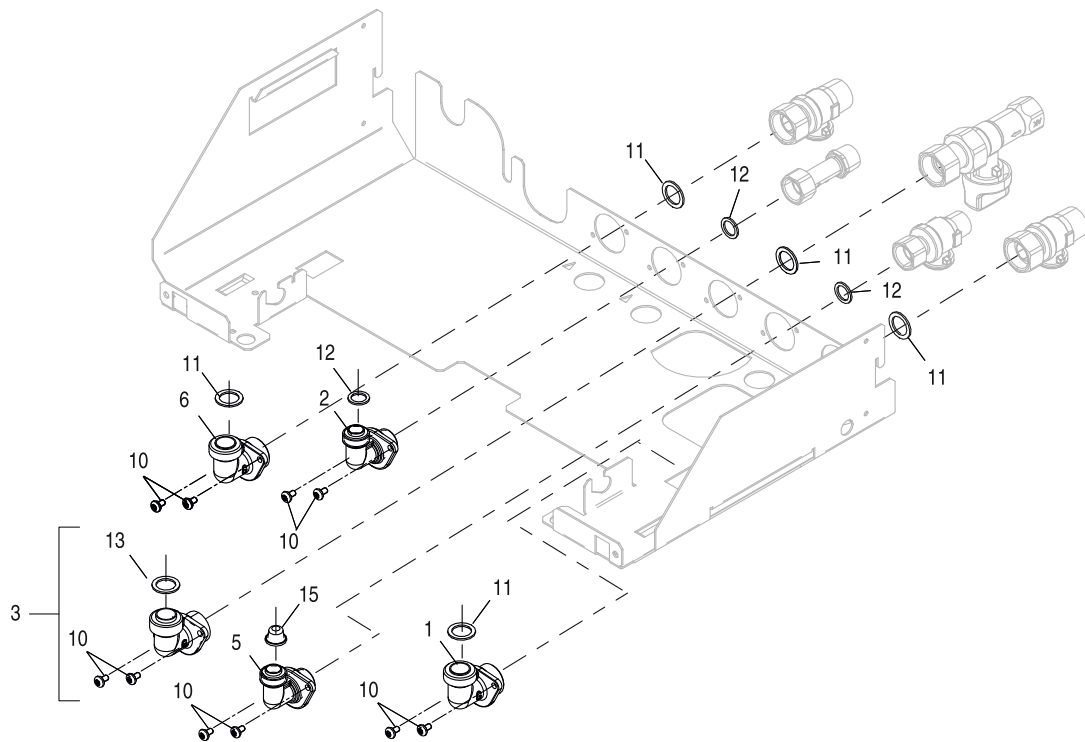

8716799166.ab.MAFP

**7B**

Verbindungsbögen  
 Coudes de raccordement  
 Gomiti di connessione  
 Connection elbows

**GB172i-24 T50 . . / GB192i-24 T50 . .**  
**Logamax plus**



Pos	Bezeichnung Dénomination Descrizioni Description	Bestell-Nr. Numéro de commande N° d'ordine Ordering no.																			Bemerkungen Remarques Osservazioni Remarks
			7716701553																		
			7716701559																		
			7716701566																		
			7716701567																		
			7716701570																		
			7716701571																		
			7716701574																		
			7716701577																		
			7716701585																		
			7716701586																		
1	Anschlussstück	8 716 156 758 0	■	■	■	■	■														
2	Anschlussstück	8 713 305 610 0	■	■	■	■	■														
3	Gasbogen	8 716 766 642	■	■	■	■	■														
5	Anschlussstück	8 713 305 610 0	■	■	■	■	■														
6	Anschlussstück	8 716 156 758 0	■	■	■	■	■														
10	Schraube (10x)	8 718 642 109 0	■	■	■	■	■														
11	Dichtung 23,9x17,2x1,5 (10x)	8 710 103 043 0	■	■	■	■	■														
12	Dichtung 18,6x13,5x1,5 (10x)	8 710 103 045 0	■	■	■	■	■														
13	Dichtung 18,3x24,3 (10x)	8 710 103 161 0	■	■	■	■	■														
15	Filter (10x)	8 716 766 126	■	■	■	■	■														

**GB172i-24 T50 . . / GB192i-24 T50 . .**  
**Logamax plus**

Verbindungsbögen  
Coudes de raccordement  
Gomiti di connessione  
Connection elbows

**7B**

**Ersatzteilliste**  
**Liste des pièces de rechange**

**Lista parti di ricambio**  
**Spare parts list**

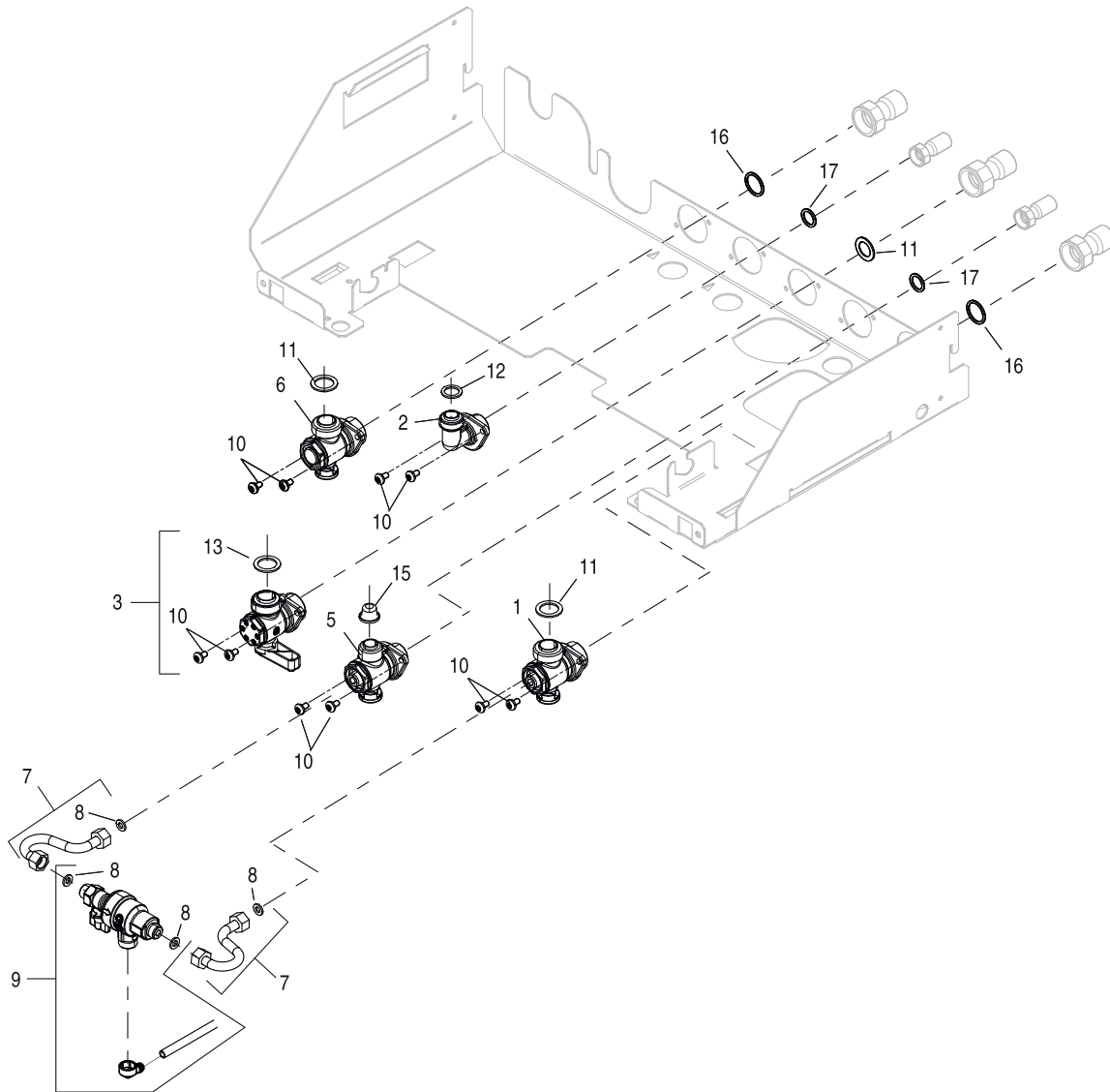

8716799182.ab.MAFP

**7C**

Absperrventil  
 Raccordement vannes  
 Collegamento valvola  
 Connection shut-off valve

**GB172i-24 T50 . . / GB192i-24 T50 . .**  
**Logamax plus**

Pos	Bezeichnung Dénomination Descrizioni Description	Bestell-Nr. Numéro de commande N° d'ordine Ordering no.											Bemerkungen Remarques Osservazioni Remarks						
			7716701553	7716701559	7716701566	7716701567	7716701570	7716701571	7716701574	7716701577	7716701585	7716701586							
1	Ventil	8 716 156 759 0							■	■	■	■							
2	Anschlussstück	8 713 305 610 0							■	■	■	■							
3	Gashahn	8 716 747 341							■	■	■	■							
5	Ventil	8 716 771 286 0							■	■	■	■							
6	Wasserarmatur 3/4"	8 716 771 633 0							■	■	■	■							
7	Rohr Disconnecteur	8 716 762 262 0							■	■	■	■							
8	Dichtung 6x11x1,5 (10x)	8 710 103 123 0							■	■	■	■							
9	Fülleinrichtung	8 716 770 004 0							■	■	■	■							
10	Schraube (10x)	8 718 642 109 0							■	■	■	■							
11	Dichtung 23,9x17,2x1,5 (10x)	8 710 103 043 0							■	■	■	■							
12	Dichtung 18,6x13,5x1,5 (10x)	8 710 103 045 0							■	■	■	■							
13	Dichtung 18,3x24,3 (10x)	8 710 103 161 0							■	■	■	■							
15	Filter (10x)	8 716 766 126							■	■	■	■							
16	Dichtscheibe 3/4" (10x)	8 710 103 117 0							■	■	■	■							
17	Dichtscheibe 1/2" (10x)	8 710 103 116 0							■	■	■	■							



<b>GB172i-24 T50 . . / GB192i-24 T50 . .</b> <b>Logamax plus</b>	Absperrventil Raccordement vannes Collegamento valvola Connection shut-off valve	<b>7C</b>
---	---	-----------

**Ersatzteilliste**  
**Liste des pièces de rechange**

**Lista parti di ricambio**  
**Spare parts list**

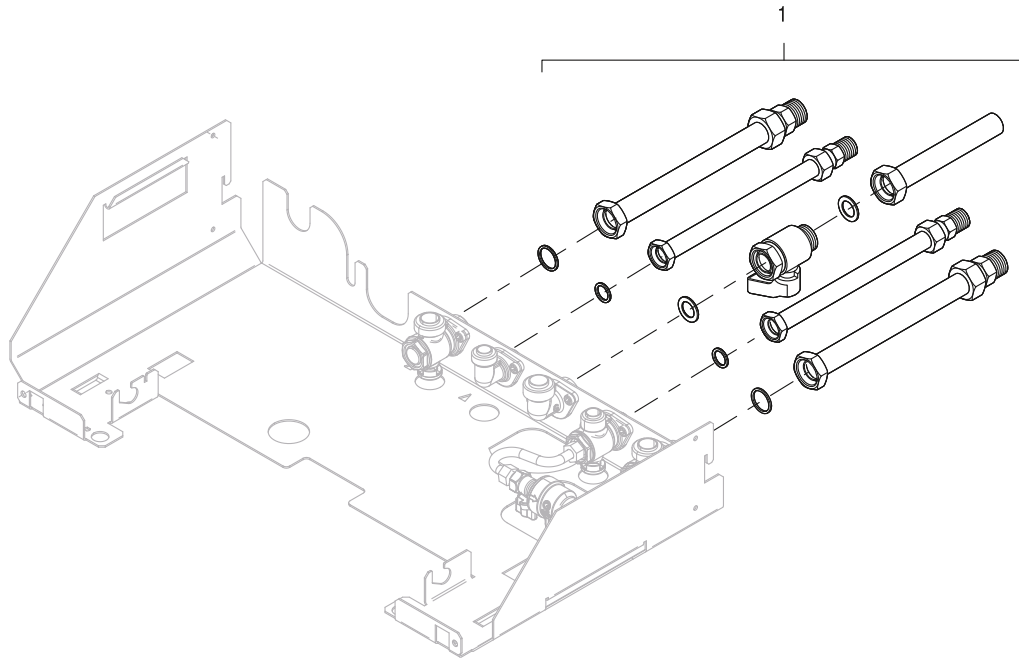

8716799177.aa.MAFP

**8A**

Rohranschluss  
Tubes de raccordement  
Tubo collegamento  
Connection pipes

**GB172i-24 T50 . . / GB192i-24 T50 . .**  
**Logamax plus**

Pos	Bezeichnung Dénomination Descrizioni Description	Bestell-Nr. Numéro de commande N° d'ordine Ordering no.																									Bemerkungen Remarques Osservazioni Remarks																																																																																																																																																																																																																																																																																																								
1	HW-SetBC-2	7 716 780 442		7716701553	7716701559	7716701566	7716701567	7716701570	7716701571	7716701574	7716701577	7716701585	7716701586																																																																																																																																																																																																																																																																																																																						
GB172i-24 T50 . . / GB192i-24 T50 . . Logamax plus																																																																																																																																																																																																																																																																																																																								Rohranschluss Tubes de raccordement Tubo collegamento Connection pipes											

**8A**

**Ersatzteilliste**  
**Liste des pièces de rechange**

**Lista parti di ricambio**  
**Spare parts list**

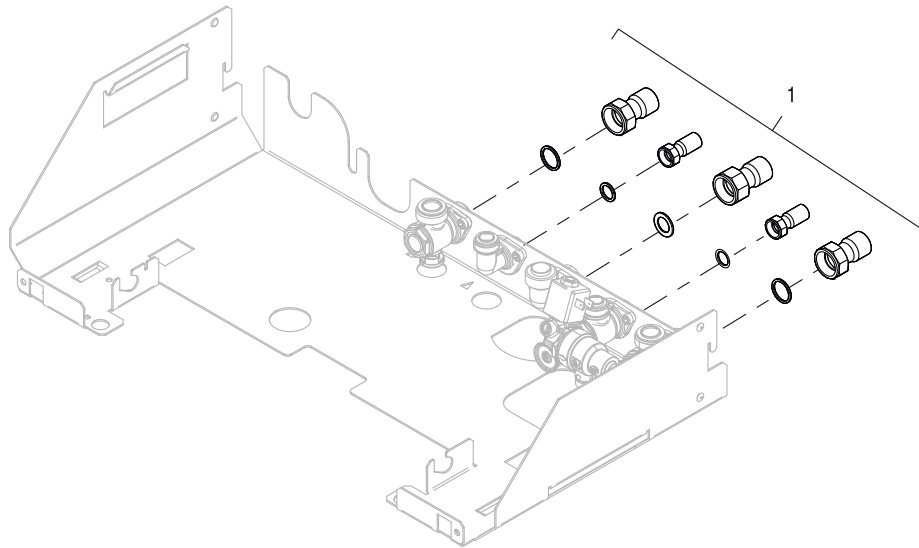
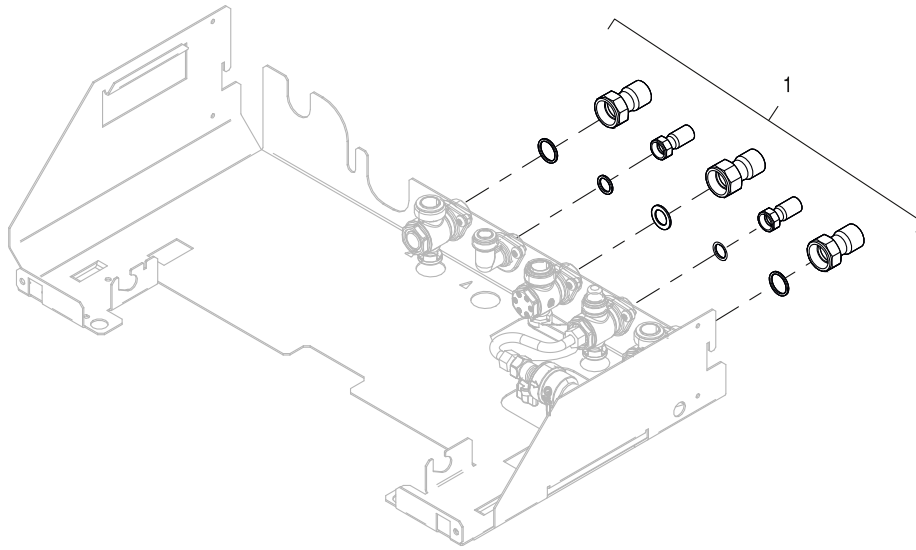

8716799178.aa.MAFP

**8B**

Rohranschluss  
Tubes de raccordement  
Tubo collegamento  
Connection pipes

**GB172i-24 T50 . . / GB192i-24 T50 . .**  
**Logamax plus**

Pos	Bezeichnung Dénomination Descrizioni Description	Bestell-Nr. Numéro de commande N° d'ordine Ordering no.																									Bemerkungen Remarques Osservazioni Remarks
1	HW-SetBC-3	7 716 780 443	7716701563	7716701569	7716701566	7716701567	7716701570	7716701571	7716701574	7716701577	7716701585	7716701586															
<b>GB172i-24 T50 . . / GB192i-24 T50 . .</b> <b>Logamax plus</b>											Rohranschluss Tubes de raccordement Tubo collegamento Connection pipes											<b>8B</b>					

**Ersatzteilliste**  
**Liste des pièces de rechange**

**Lista parti di ricambio**  
**Spare parts list**

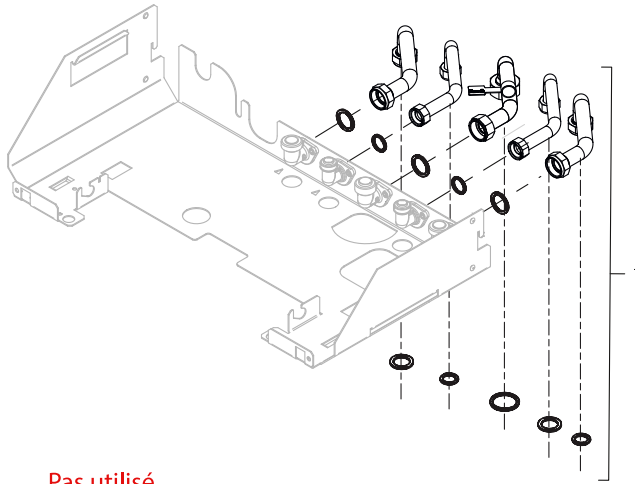
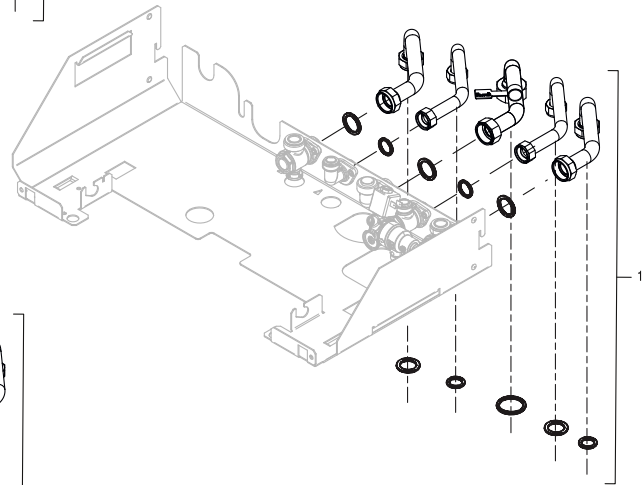
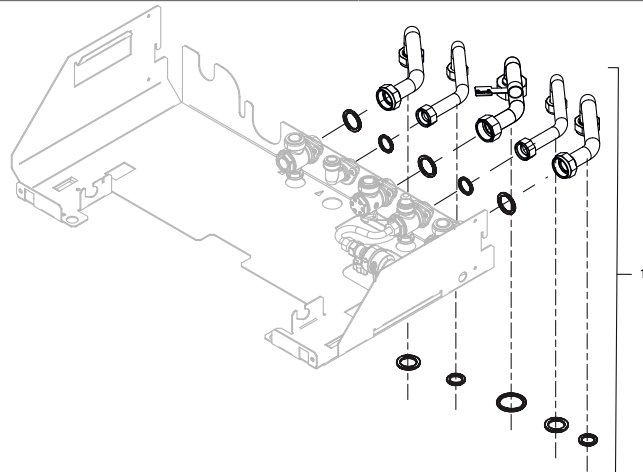

Pas utilisé

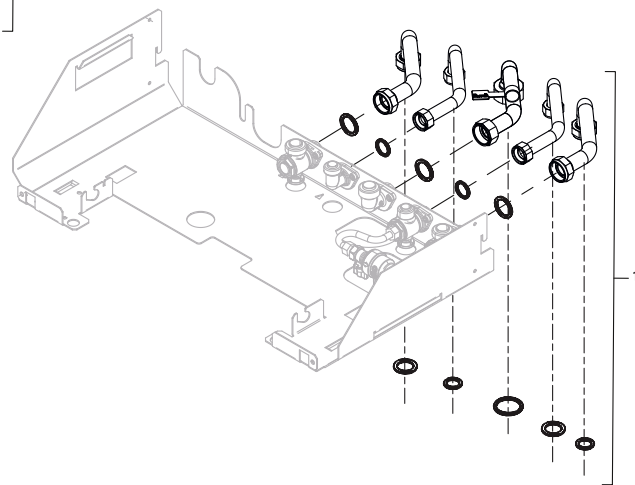

8716799168.ab.MAFP

**8C**

Rohranschluss  
 Tubes de raccordement  
 Tubo collegamento  
 Connection pipes

**GB172i-24 T50 . . / GB192i-24 T50 . .**  
**Logamax plus**



Pos	Bezeichnung Dénomination Descrizioni Description	Bestell-Nr. Numéro de commande N° d'ordine Ordering no.	7716701553	7716701559	7716701566	7716701567	7716701570	7716701571	7716701574	7716701577	7716701585	7716701586							Bemerkungen Remarques Osservazioni Remarks
1	HW-SetBC-5	7 716 780 190	■	■	■	■	■	■	■	■	■	■							
1	HW-SetBC-4	7 716 780 440	■																

<b>GB172i-24 T50 . . / GB192i-24 T50 . .</b> <b>Logamax plus</b>	Rohranschluss Tubes de raccordement Tubo collegamento Connection pipes	<b>8C</b>
---	---	-----------

**Ersatzteilliste**  
**Liste des pièces de rechange**

**Lista parti di ricambio**  
**Spare parts list**

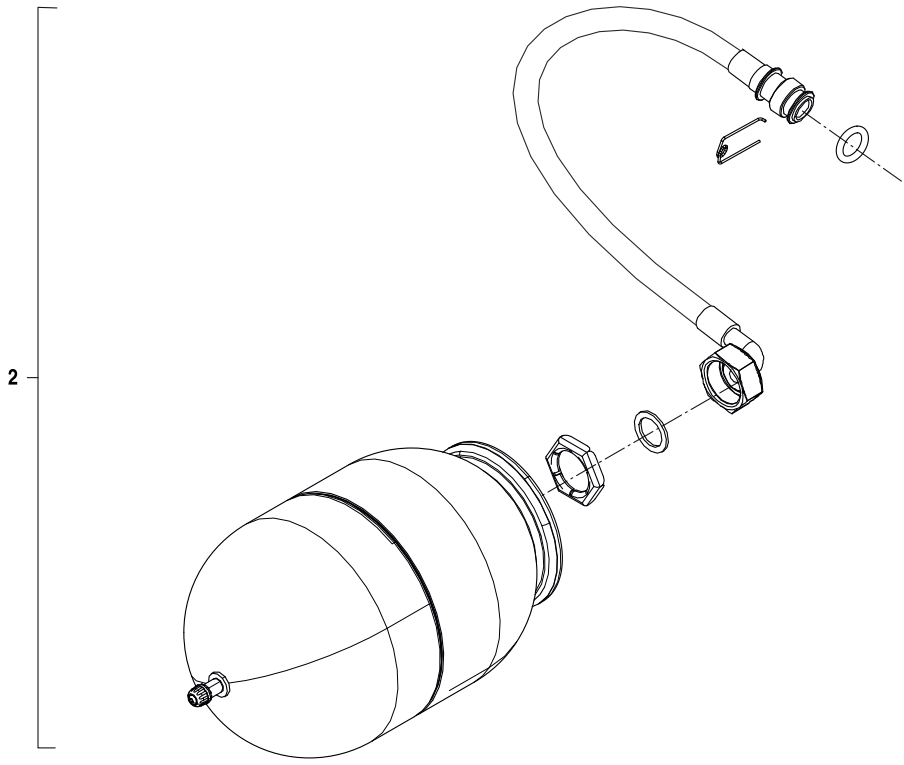
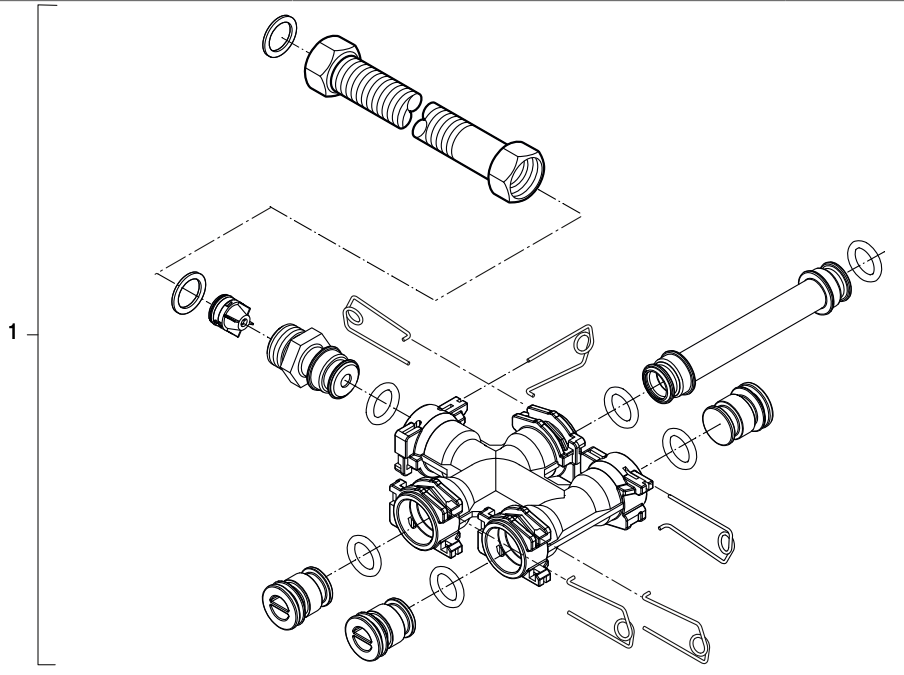

8716799169.ab.MAFP

**9** Recyclinganschluss/Ausdehnungsgefäß  
 Boucle de recyclage/Vase d'expansion  
 Riciclaggio collegame./Vaso d'espansione  
 Recycling Connection/Expansion vessel

**GB172i-24 T50 . . / GB192i-24 T50 . .**  
**Logamax plus**

Pos	Bezeichnung Dénomination Descrizioni Description	Bestell-Nr. Numéro de commande N° d'ordine Ordering no.																	Bemerkungen Remarques Osservazioni Remarks
			7716701553																
			7716701559																
			7716701566																
			7716701567																
			7716701570																
			7716701571																
			7716701574																
			7716701577																
			7716701585																
			7716701586																
1	IW-SetCI-1	7 716 780 456	■	■	■	■	■	■	■	■	■								
2	IW-EVD2	7 716 780 455	■						■	■									

<b>GB172i-24 T50 . . / GB192i-24 T50 . .</b> <b>Logamax plus</b>	Recyclinganschluss/Ausdehnungsgefäß Boucle de recyclage/Vase d'expansion Riciclaggio collegame./Vaso d'espansione Recycling Connection/Expansion vessel	<b>9</b>
---	--	----------

**Übersetzungsliste**  
**Liste des traductions**

**Traduzione delle descrizioni**  
**List of translations**

Pos	Denomination	Descrizione	Description		
<b>1</b>	<b>Groupe de construction</b>	<b>Gruppo di costruzione</b>	<b>Element of construction</b>		
1	Panneau De Façade Buderus	Pannello Anteriore Buderus	Front Panel Buderus		
1	Panneau Avant HPP Square White ASS FR	Pannello HPP Buderus bianco	Panel Front HPP Square White ASS FR		
3	Panneau Latéral (SQ Droit Blanc+Mousse)	Pannello Laterale (SQ Bianco a destra+Sc	Side Panel (SQ Right White + Foam)		
3	Panneau Latéral (SQ Droit Argent+Mousse)	Pannello Laterale (SQ legge d'argento+Sc	Side Panel (SQ Right Silver + Foam)		
4	Panneau Latéral (SQ Gauche Blanc+Mousse)	Pannello Laterale (SQ Sin.Bianco+Schiuma	Side Panel (SQ Left White + Foam)		
4	Panneau Latéral (SQ gauche Argent+Mousse	Pannello Laterale (SQ legge d'argento+Sc	Side Panel (SQ Left Silver + Foam)		
5	Vase d'expansion GB072 14-24(k)/ GB172	Vaso di espansione	Expansion vessel		
6	Joint torique 13,87x3,53 L (10x)	O-ring 13,87x3,53 L (10x)	O-ring 13,87x3,53 L (10x)		
7	Joint 18,6x13,5x1,5 (10x)	Guarnizione 18,6x13,5x1,5 (10x)	Gasket 18,6x13,5x1,5 (10x)		
8	Flexible De Vase Expansion CH	Tubo Ondulato	Pipe Corrugated Pipe		
9	Sortie Fumée Inférieure	Uscita Fumi Inferiore	Lower Flue Gas Outlet		
10	Sortie Fumée Supérieure	Uscita Fumi Superiore	Upper Flue Gas Outlet		
11	Protection anti-pluie	Copertura	Covering sheet		
12	Support sortie fumée	Condotto fumi	Support Upper Flue		
13	Vis No.10x20 Hex tête de bride (3x)	Vite No.10x20 Hex testa flangia (3x)	Screw No.10x20 Hex Flange Head (3x)		
14	Ecrou 4,8mm (10x)	Dado 4,8mm (10x)	Nut 4,8mm (10x)		
15	Tube Silicone	Tubo Di Silicone	Silicone Pipe		
16	Dispositif De Verrouillage Panneau	Dispositivo Di Bloccaggio Del Pannello	Panel locking device		
17	Couvercle De Caisson	Coperchio Di Chiusura	Cover Front Air Casing		
18	Support Attache	Sostegno Clip	Fixing Cradle Bracket Clip		
19	Verrou Tableau Electrique	Pannello Di Controllo Con Serratura	Control Panel Lock		
20	Support appareil de contrôle	Sostegno unità di controllo	Control_box Cradle assembly		
21	Vis	Vite	Screw M 5.0X20 DIN 7985		
22	Cache (Accès installateur)	Copertura (Accesso installatore)	Cover (Installer access)		
23	Cache (Ip PluX)	Copertura (Ip PluX)	Cover (Ip PluX)		
24	Verrou (PluX)	Chiusura (PluX)	Lock (PluX)		
25	Serre-câble	Ferma cavo	Strain relief		
26	Passe-câbles 2-pôles	Passacavo 2-bipolare	Grommet feed 2-pole		
27	Plaque d'Accrochage	Traversa	Fixing bracket		
28	Epingle 18mm (10x)	Molletta di ritenzione 18mm (10x)	Clip 18mm (10x)		
29	Adapt concentrique prise mesure Ø80/125	Adatt-part-vert_80/125_PP/Met	Adapter concentric Ø80/125		

**Übersetzungsliste**  
**Liste des traductions**

**Traduzione delle descrizioni**  
**List of translations**

Pos	Denomination	Descrizione	Description		
30	Bouchon a/joint	Coperchietto	Grommet		
31	Joint D80	Guarnizione D80	Seal D80		
32	Joint DN125	Labbro della guarnizione DN125	Lipseal DN125		
33	Vis 4,8x30 (3x)	Vite 4,8x30 (3x)	Screw 4,8x30 (3x)		
<b>2</b>	<b>Groupe de construction</b>	<b>Gruppo di costruzione</b>	<b>Element of construction</b>		
1	Echangeur Thermique 30kW	Scambiatore Di Calore 30kW	30kW Heat Exchanger		
2	Jeu d'électrodes	Set di elettrodi	Electrode set		
3	Joint brûleur	Guarnizione bruciatore	Seal burner		
4	Brûleur 30 kW	Bruciatore 30 kW	Burner 30 kW		
5	Défecteur Supérieur	Corpo di spostamento	Displacement body		
6	Défecteur Inférieur	Corpo di spostamento	Lower baffle		
7	Joint	Guarnizione	Seal		
8	Collecteur Condensat Equipé	Imbuto Di Scarico Attrezzato	Equipped Condensate Collector		
9	Passe-fil	Anello di gomma	Grommet		
10	Collecteur Condensat	Imbuto Di Scarico	Condensate Collector		
11	Joint Semelle / Sortie	Gomma Di Tenuta	Seal Rubber		
12	Sortie Fumée WB6 Equipé	Collettore Fumi	Flue Gas Collector Duct		
13	Ecrou	Sostegno	Nut		
14	Limiteur de température	Limitatore di temperatura	Temperature limiter		
15	Vis CB M5 X 20 Inox	Vite	Screw		
16	Vis M6x18 (10x)	Vite M6x18 (10x)	Screw M6x18 (10x)		
17	Support Echangeur Thermique	Scambiatore Di Calore Di Supporto	Support Heat Exchanger		
18	Tube Sortie Supérieur C6	Tubazione Di Mandata C6 (Superiore)	Top Outlet Pipe C6		
19	Clip tube (x10)	Clip a innesto a U (10x)	Clip (10x)		
20	Joint torique 17x4 (10x)	O-ring 17x4 (10x)	O-ring 17x4 (10x)		
21	Ensemble Dégazeur-Coude Corps de Chauffe	Deaeratore-Gruppo riscaldatore a gomito	Deaerator-Heat Exchanger Elbow Assembly		
22	Sonde de température 18mm	Sensore termometrico 18mm	Sensor 18mm		
23	Tube Entrée C6	Tubo Di Ritorno C6	Pipe Inlet C6		
23	Tube Entrée C6 COIL	Tubo Di Ritorno C6 COIL	Pipe inlet C6 COIL		
24	Connecteur Siphon Assemblé	Collegamento Al Sifone	Syphon Connector Assembled		
25	Siphon	Sifone	Trap Assembly		
26	Tuyau	Tubo flessibile	Hose		

**Übersetzungsliste**  
**Liste des traductions**

**Traduzione delle descrizioni**  
**List of translations**

Pos	Denomination	Descrizione	Description		
27	Joint	Guarnizione	Seal siphon		
28	Sonde de température NTC	Sonda di temperatura NTC	Temperature sensor NTC		
29	Ecrou M8	Dado M8	Nut M8		
30	Limiteur de température	Limitatore temperatura	Temperature limiter		
31	Câble d'allumage	Cavo d'accensione	Ignition Cable		
32	Transformateur d'allumage	Trasformatore d'accensione	Ignition transformer		
33	Epingle 18mm (10x)	Molletta di ritenzione 18mm (10x)	Clip 18mm (10x)		
34	Joint 18,5x24,3 (10x)	Guarnizione 18,5x24,3 (10x)	Seal 18,5x24,3 (10x)		
35	Tube Sortie Inferieur C6	Tubazione Di Mandata C6 (Inferiore)	Lower Outlet Pipe C6		
36	Sonde De Température	Sensore Termometrico	Temperature Sensor		
37	Joint torique 8 x2 (x10)	Anello tenuta 8x2 (10x)	O-ring 8x2 (10x)		
38	Epingle (10x)	Molletta di ritenzione (10x)	Clip (10x)		
39	Purgeur+cup	Disaeratore	Air vent		
40	Kit Entretien	Manutenzione Set	Service Kit		
<b>3</b>	<b>Groupe de construction</b>	<b>Gruppo di costruzione</b>	<b>Element of construction</b>		
1	Ventilateur	Ventilatore	Fan		
2	Bloc gaz	Valvola del gas	Gas valve		
3	Venturi 30 kW G20/G31	Venturi 30 kW G20/G31	Venturi 30 kW G20/G31		
3	Venturi 30 kW G25/GZ35A	Venturi 30 kW G25/GZ35A	Venturi 30 kW G25/GZ35A		
4	Volet De Protection	Guarnizione flap	Flap Guard		
5	Clapet anti-retour	Valvola di non ritorno	Non-return valve		
6	Coude Sortie Ventilateur	Condotto Del Ventilatore	Fan Elbow Outlet		
7	Joint (Ventilateur)	Guarnizione (Ventilatore)	Seal (Fan)		
8	Joint	Guarnizione	Seal		
9	Vis M5x15 (3x)	Vite M5x15 (3x)	Screw M5x15 (3x)		
10	Vis 4x15 (10x)	Vite 4x15 (10x)	Screw 4x15 (10x)		
11	Capuchon (1x)	Tappo (1x)	Cap (1x)		
12	Conduit d'aspiration d'air	Tubo aspirazione aria	Suction pipe		
13	Joint torique NBR 29x2 (10x)	O-ring NBR 29x2 (10x)	O-ring NBR 29x2 (10x)		
14	Tube gaz coude	Tubo Gas	Tube - Gas Supply		
15	Injecteur 30 kW G31	Iniettore 30 kW G31	Nozzle 30 kW G31		
15	Injecteur gaz 30kW G20	Ugello del gas 30kW G20	Orifice 30kW G20		

**Übersetzungsliste**  
**Liste des traductions**

**Traduzione delle descrizioni**  
**List of translations**

Pos	Denomination	Descrizione	Description		
15	Injecteur 30 kW G20 / G25	Iniettore 30 kW G20 / G25	Nozzle 30 kW G20 / G25		
16	Ecrou	Dado	Nut		
17	Joint gaz valve 41x3 (10x)	Guarnizione valvola gas 41x3 (10x)	Gasket Gas valve 41x3 (10x)		
18	Tube Gaz	Tubo Gas	Pipe Gas		
19	Couvercle mélange gaz-air	Canale miscela aira-gas	Duct gas-air mixture		
20	Vis M8x45 (10x)	Vite M4x8 (10x)	Screw M4x8 (10x)		
21	Cosse de masse 6.3	Connector 6.3 maschio Clamp Piatto	Connector 6.3 Male		
22	Joints 18,3x24,3 (10x)	Guarnizione 18,3x24,3 (10x)	Washer 18,3x24,3 (10x)		
<b>4A</b>	<b>Groupe de construction</b>	<b>Gruppo di costruzione</b>	<b>Element of construction</b>		
1	Collecteur	Collettore	Manifold plate		
2	Joint 28,4x8 (x10)	Guarnizione 28,4x8 (10x)	Seal 28,4x8 (10x)		
3	Joint 19,4x8 (10x)	Guarnizione 19,4x8 (10x)	Seal 19,4x8 (10x)		
4	Vis M5x35 (10x)	Vite M5x35 (10x)	Screw M5x35 (10x)		
5	Bouchon (5x)	Tappo (5x)	Plug (5x)		
6	Joint torique 12,5 x3 wras / ktw (1x)	Anello tenuta 12,5x3 WRAS / KTW (1x)	O-ring 12,5x3 WRAS / KTW (1x)		
7	Epingle 13mm	Molletta di ritenzione 13mm	Clip 13mm		
8	Echangeur thermique	Scambiatore di calore	Heat Exchanger PHE C SH 24 ASM 1P FF		
9	Tube	Tubo	Pipe CH Flow		
10	Joint torique 17x4 (10x)	O-ring 17x4 (10x)	O-ring 17x4 (10x)		
11	Epingle 18mm (10x)	Molletta di ritenzione 18mm (10x)	Clip 18mm (10x)		
12	Joint torique 13,87x3,53 L (10x)	O-ring 13,87x3,53 L (10x)	O-ring 13,87x3,53 L (10x)		
13	Tube retour	Tubo di ritorno	Return pipe		
14	Robinet de vidange	Rubinetto di carico	Filling valve		
15	Joint torique 18,7x2,7 (10x)	O-ring 18,7x2,7 (10x)	O-ring 18,7x2,7 (10x)		
16	Epingle (10x)	Molletta di ritenzione (10x)	Clip (10x)		
17	Tube	Tubo	Assembly CH return H120 pipe assy		
18	Vanne 3 voies	Organo 3 vie	3-way valve		
19	Epingle (10x)	Molletta di ritenzione (10x)	Clip (10x)		
20	Joint torique 23,47x2,62 (10x)	O-ring 23,47x2,62 (10x)	O-ring 23,47x2,62 (10x)		
21	Clip (10x)	Clip di ritenzione (10x)	Clip (10x)		
22	Joint torique 23x4 (10x)	O-ring 23x4 (10x)	O-ring 23x4 (10x)		
23	Epingle 10mm (10x)	Molletta di ritenzione 10mm (10x)	Clip 10mm (10x)		

**Übersetzungsliste**  
**Liste des traductions**

**Traduzione delle descrizioni**  
**List of translations**

Pos	Denomination	Descrizione	Description		
24	Tube de raccordement	Tubo di collegamento	Connecting pipe		
25	Epingle (10x)	Molletta di ritenzione (10x)	Clip (10x)		
26	Clip tube (10x)	Clip a innesto a U (10x)	Clip (10x)		
27	Joint torique 20,22x3,53 EPDM (10x)	O-ring 20,22x3,53 EPDM (10x)	O-ring 20,22x3,53 EPDM (10x)		
28	Pompe ErP SpE HU2-10	Pompa ErP SpE HU2-10	Pump ErP SpE HU2-10		
29	Volute pompe (Manifold plate)	Tubo	Manifold plate		
30	Joint torique 34x3 (10x)	O-ring 34x3 (10x)	O-ring 34x3 (10x)		
31	Vis M5x30 + Rondelle	Vite M5x30 + Rondella	Screw M5x30 + Washer		
32	Raccordement (Vase d'expansion)	Collegamento (Vaso d'espansione)	Manifold (Expansion vessel)		
33	Clip de verrouillage	Molla di bloccaggio 10 millimetri	Spring Locking 10mm		
34	Capteur de pression	Sonda di pressione	Pressure sensor		
35	Soupape de sécurité	Valvola di sicurezza	Pressure relief valve		
36	Tube de raccordement	Tubo di collegamento	Connecting pipe (PRV)		
37	Joint 23,9x17,2x1,5 (10x)	Guarnizione 23,9x17,2x1,5 (10x)	Gasket 23,9x17,2x1,5 (10x)		
38	Joint 18,5x24,3 (10x)	Guarnizione 18,5x24,3 (10x)	Seal 18,5x24,3 (10x)		
39	Coude	Curva	Elbow		
40	Tuyau d'evacuation	Tubo flessibile	Hose		
41	Manomètre	Manometro	Pressure gauge		
42	Joint torique 2,62x6,02 WRAS / KTW (10x)	O-ring 2,62x6,02 WRAS / KTW (10x)	O-ring 2,62x6,02 WRAS / KTW (10x)		
<b>4B</b>	<b>Groupe de construction</b>	<b>Gruppo di costruzione</b>	<b>Element of construction</b>		
5	Bouchon (5x)	Tappo (5x)	Plug (5x)		
6	Joint torique 12,5 x3 wras / ktw (1x)	Anello tenuta 12,5x3 WRAS / KTW (1x)	O-ring 12,5x3 WRAS / KTW (1x)		
7	Epingle 13mm	Molletta di ritenzione 13mm	Clip 13mm		
10	Joint torique 17x4 (10x)	O-ring 17x4 (10x)	O-ring 17x4 (10x)		
11	Epingle 18mm (10x)	Molletta di ritenzione 18mm (10x)	Clip 18mm (10x)		
12	Joint torique 13,87x3,53 L (10x)	O-ring 13,87x3,53 L (10x)	O-ring 13,87x3,53 L (10x)		
13	Tube retour	Tubo di ritorno	Return pipe		
14	Robinet de vidange	Rubinetto di carico	Filling valve		
15	Joint torique 18,7x2,7 (10x)	O-ring 18,7x2,7 (10x)	O-ring 18,7x2,7 (10x)		
16	Epingle (10x)	Molletta di ritenzione (10x)	Clip (10x)		
17	Tube	Tubo	Assembly CH return H120 pipe assy		
18	Vanne 3 voies	Organo 3 vie	3-way valve		



**Übersetzungsliste**  
**Liste des traductions**

**Traduzione delle descrizioni**  
**List of translations**

Pos	Denomination	Descrizione	Description		
19	Epingle (10x)	Molletta di ritenzione (10x)	Clip (10x)		
20	Joint torique 23,47x2,62 (10x)	O-ring 23,47x2,62 (10x)	O-ring 23,47x2,62 (10x)		
21	Clip (10x)	Clip di ritenzione (10x)	Clip (10x)		
22	Joint torique 23x4 (10x)	O-ring 23x4 (10x)	O-ring 23x4 (10x)		
23	Epingle 10mm (10x)	Molletta di ritenzione 10mm (10x)	Clip 10mm (10x)		
24	Tube de raccordement	Tubo di collegamento	Connecting pipe		
25	Epingle (10x)	Molletta di ritenzione (10x)	Clip (10x)		
26	Clip tube (10x)	Clip a innesto a U (10x)	Clip (10x)		
27	Joint torique 20,22x3,53 EPDM (10x)	O-ring 20,22x3,53 EPDM (10x)	O-ring 20,22x3,53 EPDM (10x)		
28	Pompe ErP SpE HU2-10	Pompa ErP SpE HU2-10	Pump ErP SpE HU2-10		
29	Volute pompe (Manifold plate)	Tubo	Manifold plate		
30	Joint torique 34x3 (10x)	O-ring 34x3 (10x)	O-ring 34x3 (10x)		
31	Vis M5x30 + Rondelle	Vite M5x30 + Rondella	Screw M5x30 + Washer		
32	Raccordement (Vase d'expansion)	Collegamento (Vaso d'espansione)	Manifold (Expansion vessel)		
33	Clip de verrouillage	Molla di bloccaggio 10 millimetri	Spring Locking 10mm		
34	Capteur de pression	Sonda di pressione	Pressure sensor		
35	Soupape de sécurité	Valvola di sicurezza	Pressure relief valve		
36	Tube de raccordement	Tubo di collegamento	Connecting pipe (PRV)		
37	Joint 23,9x17,2x1,5 (10x)	Guarnizione 23,9x17,2x1,5 (10x)	Gasket 23,9x17,2x1,5 (10x)		
38	Joint 18,5x24,3 (10x)	Guarnizione 18,5x24,3 (10x)	Seal 18,5x24,3 (10x)		
39	Coude	Curva	Elbow		
40	Tuyau d evacuation	Tubo flessibile	Hose		
41	Manomètre	Manometro	Pressure gauge		
42	Joint torique 2,62x6,02 WRAS / KTW (10x)	O-ring 2,62x6,02 WRAS / KTW (10x)	O-ring 2,62x6,02 WRAS / KTW (10x)		
<b>4C</b>	<b>Groupe de construction</b>	<b>Gruppo di costruzione</b>	<b>Element of construction</b>		
5	Bouchon (5x)	Tappo (5x)	Plug (5x)		
6	Joint torique 12,5 x3 wras / ktw (1x)	Anello tenuta 12,5x3 WRAS / KTW (1x)	O-ring 12,5x3 WRAS / KTW (1x)		
7	Epingle 13mm	Molletta di ritenzione 13mm	Clip 13mm		
10	Joint torique 17x4 (10x)	O-ring 17x4 (10x)	O-ring 17x4 (10x)		
11	Epingle 18mm (10x)	Molletta di ritenzione 18mm (10x)	Clip 18mm (10x)		
12	Joint torique 13,87x3,53 L (10x)	O-ring 13,87x3,53 L (10x)	O-ring 13,87x3,53 L (10x)		
13	Tube retour	Tubo di ritorno	Return pipe		

**Übersetzungsliste**  
**Liste des traductions**

**Traduzione delle descrizioni**  
**List of translations**

Pos	Denomination	Descrizione	Description		
14	Robinet de vidange	Rubinetto di carico	Filling valve		
15	Joint torique 18,7x2,7 (10x)	O-ring 18,7x2,7 (10x)	O-ring 18,7x2,7 (10x)		
16	Epingle (10x)	Molletta di ritenzione (10x)	Clip (10x)		
17	Tube	Tubo	Assembly CH return H120 pipe assy		
18	Vanne 3 voies	Organo 3 vie	3-way valve		
19	Epingle (10x)	Molletta di ritenzione (10x)	Clip (10x)		
20	Joint torique 23,47x2,62 (10x)	O-ring 23,47x2,62 (10x)	O-ring 23,47x2,62 (10x)		
21	Clip (10x)	Clip di ritenzione (10x)	Clip (10x)		
22	Joint torique 23x4 (10x)	O-ring 23x4 (10x)	O-ring 23x4 (10x)		
23	Epingle 10mm (10x)	Molletta di ritenzione 10mm (10x)	Clip 10mm (10x)		
24	Tube de raccordement	Tubo di collegamento	Connecting pipe		
25	Epingle (10x)	Molletta di ritenzione (10x)	Clip (10x)		
26	Clip tube (10x)	Clip a innesto a U (10x)	Clip (10x)		
27	Joint torique 20,22x3,53 EPDM (10x)	O-ring 20,22x3,53 EPDM (10x)	O-ring 20,22x3,53 EPDM (10x)		
28	Pompe ErP SpE HU2-10	Pompa ErP SpE HU2-10	Pump ErP SpE HU2-10		
29	Volute pompe (Manifold plate)	Tubo	Manifold plate		
30	Joint torique 34x3 (10x)	O-ring 34x3 (10x)	O-ring 34x3 (10x)		
31	Vis M5x30 + Rondelle	Vite M5x30 + Rondella	Screw M5x30 + Washer		
32	Raccordement (Vase d'expansion)	Collegamento (Vaso d'espansione)	Manifold (Expansion vessel)		
33	Clip de verrouillage	Molla di bloccaggio 10 millimetri	Spring Locking 10mm		
34	Capteur de pression	Sonda di pressione	Pressure sensor		
35	Soupape de sécurité	Valvola di sicurezza	Pressure relief valve		
36	Tube de raccordement	Tubo di collegamento	Connecting pipe (PRV)		
37	Joint 23,9x17,2x1,5 (10x)	Guarnizione 23,9x17,2x1,5 (10x)	Gasket 23,9x17,2x1,5 (10x)		
38	Joint 18,5x24,3 (10x)	Guarnizione 18,5x24,3 (10x)	Seal 18,5x24,3 (10x)		
39	Coude	Curva	Elbow		
40	Tuyau d evacuation	Tubo flessibile	Hose		
41	Manomètre	Manometro	Pressure gauge		
42	Joint torique 2,62x6,02 WRAS / KTW (10x)	O-ring 2,62x6,02 WRAS / KTW (10x)	O-ring 2,62x6,02 WRAS / KTW (10x)		
43	Système remplissage / vidange	Dispositivo Di Carico E Scarico	Fill and Drain Unit		
44	robinet de remplissage et de vidange	rubinetto di carico e scarico	Fill and drain cock		
45	Epingle D15	Staffa D15	Clip D15		

**Übersetzungsliste**  
**Liste des traductions**

**Traduzione delle descrizioni**  
**List of translations**

Pos	Denomination	Descrizione	Description		
46	Joint torique 15,88x2,62mm (10x)	Anello tenuta 15,88x2,62mm (10x)	O-ring 15,88x2,62mm (10x)		
<b>5</b>	<b>Groupe de construction</b>	<b>Gruppo di costruzione</b>	<b>Element of construction</b>		
1	Tableau électrique ACU MHP-23	Centralina ACU MHP-23	Control unit ACU MHP-23		
1	Tableau électrique ACU MHP-20	Centralina ACU MHP-20	Control unit ACU MHP-20		
2	Faisceau De Câbles Basse Tension COIL	Cablaggi a bassa tensione	Low Voltage Cable Harness COIL		
2	Faisceau de câbles basse tension SLS	Cablaggi a bassa tensione	Harness Low Voltage SLS		
3	Faisceau De Cable Haute Tension	Cablaggio Per Cavi Ad Alta Tensione	High Voltage Cable Harness		
4	Kit connecteur	Kit spina	Connector Set		
5	Câble d'Alimentation Electrique Réseau	Cavo Di Rete	Power cable		
6	Faisceau Pompe Sanitaire SLS	Cablaggio Del Cavo Della Pompa Sanitaria	Sanitary Pump Cable Harness SLS		
7	Câble "Autofill"	Cavo "Autofill"	Cable auto filling link		
8	Unité de commande HMI 700	Interfaccia controllo HMI 700	Control panel HMI 700		
8	Unité de commande Logamatic BC400-FO	Interfaccia controllo Logamatic BC400-FO	Control panel Logamatic BC400-FO		
9	Cache ECO	Mascherina ECO	Facia ECO		
10	Câble + Interrupteur ON/OFF	Cavo + Interruttore ON/OFF	Cable + Switch ON/OFF		
11	Cl de codage ACP 20487 H	Chiave Di Codifica ACP 20487 H	Code Plug ACP 20487 H		
11	Cl de codage ACP 20488 LPG	Chiave Di Codifica ACP 20488 LPG	Code Plug ACP 20488 LPG		
11	Cl de codage ACP 20448 H	Chiave Di Codifica ACP 20448 H	Code_Plug ACP 20448 H		
11	Cl de codage ACP 20446 H	Chiave Di Codifica ACP 20446 H	Code_Plug ACP 20446 H		
11	Clé de codage ACP 20309 H	Chiave Di Codifica ACP 20309 H	Code_Plug ACP 20309 H		
11	Cl de codage ACP 20197 H	Chiave Di Codifica ACP 20197 H	Code_Plug ACP 20197 H		
11	Cl de codage ACP 20317 H	Chiave Di Codifica ACP 20317 H	Code Plug ACP 20317 H		
11	Cl de codage ACP 20321 H	Chiave Di Codifica ACP 20321 H	Code Plug ACP 20321 H		
11	Cl de codage ACP 20449 LPG	Chiave Di Codifica ACP 20449 LPG	Code Plug ACP 20449 LPG		
11	Cl de codage ACP 20447 LPG	Chiave Di Codifica ACP 20447 LPG	Code Plug ACP 20447 LPG		
11	Clé de codage ACP 20310 LPG	Chiave Di Codifica ACP 20310 LPG	Code Plug ACP 20310 LPG		
11	Cl de codage ACP 20198 LPG	Chiave Di Codifica ACP 20198 LPG	Code Plug ACP 20198 LPG		
11	Cl de codage ACP 20318 LPG	Chiave Di Codifica ACP 20318 LPG	Code Plug ACP 20318 LPG		
11	Cl de codage ACP 20322 LPG	Chiave Di Codifica ACP 20322 LPG	Code Plug ACP 20322 LPG		
	GCK H->LPG	GCK H->LPG	GCK H->LPG		
	GCK LPG->H	GCK LPG->H	GCK LPG->H		
	GCK H->LPG1	GCK H->LPG	GCK H->LPG		

**Übersetzungsliste**  
**Liste des traductions**

**Traduzione delle descrizioni**  
**List of translations**

Pos	Denomination	Descrizione	Description		
	GCK LPG->H	GCK LPG->H	GCK LPG->H		
	GCK H->LPG	GCK H->LPG	GCK H->LPG		
	GCK LPG->H	GCK LPG->H	GCK LPG->H		
	GCK H->G27	GCK H->G27	GCK H->G27		
	GCK H->G2.350	GCK H->G2.350	GCK H->G2.350		
	GCK H->LPG	GCK H->LPG	GCK H->LPG		
	GCK LPG->H	GCK LPG->H	GCK LPG->H		
	GCK H->LPG	GCK H->LPG	GCK H->LPG		
	GCK LPG->H	GCK LPG->H	GCK LPG->H		
	GCK H->G31	GCK H->G31	GCK H->G31		
	GCK G31->H	GCK G31->H	GCK G31->H		
<b>6A</b>	<b>Groupe de construction</b>	<b>Gruppo di costruzione</b>	<b>Element of construction</b>		
1	Ballon 42l. Inox	Bollitore ACS Inossidabile 42l.	Tank 42l. Stainless		
2	Sonde De Température	Sensore Termometrico	Temperature Sensor		
3	Ecrou CTN	Dado	Nut		
4	Isolant sonde CTN	NTC Isolante	NTC Insulation		
5	Support Vase Expansion CH	Supporto	Bracket Mounting Holder		
6	Vis M5x12 (10x)	Vite M5x12 (10x)	Screw M5x12 (10x)		
7	Tube Entrée Eau Froide Sanitaire	Tubo Acqua Fredda Sanitaria	Pipe Input Cold Water		
8	Filtre (10X)	Filtro (10x)	Filter (10x)		
9	Joint torique 13,87x3,53 (x10)	O-ring 13,87x3,53 (10x)	O-ring 13,87x3,53 (10x)		
10	Sonde de débit	Sensore di portata	Flow sensor		
11	Clip tube (x10)	Clip a innesto a U (10x)	Clip (10x)		
12	Raccord turbine - nourrice	Raccordo Turbina ACS	Flow Sensor Connector - Manifold		
13	Joint torique 15,54x2,62 (10x)	O-ring 15,54x2,62 (10x)	O-ring 15,54x2,62 (10x)		
14	Limiteur de débit 12 l/min	Flow regulator type E-W 12 l/min red	Flow regulator type E-W 12 l/min red		
15	Clapet Anti-retour D15	Valvola Di Ritegno A Clapet	Check Valve		
16	Raccord Soupape Sanitaire KTW	Raccordo	Connector		
17	Epingle 18mm (10x)	Molletta di ritenzione 18mm (10x)	Clip 18mm (10x)		
18	Soupape De Sécurité	Valvola Sicurezza	Safety Relief Valve		
19	Bouchon (5x)	Tappo (5x)	Stopper (5x)		
23	Epingle (10x)	Molletta di ritenzione (10x)	Clip (10x)		

**Übersetzungsliste**  
**Liste des traductions**

**Traduzione delle descrizioni**  
**List of translations**

Pos	Denomination	Descrizione	Description		
24	Tube Entrée Eau Froide Sanitaire Ballon	Tubo Ingresso Acqua Fredda Sanitaria	Tank Inlet Pipe		
25	Tube Entrée Echangeur A Plaques	Tubo d'ingresso Scambiatore A Piastre	Exchanger inlet pipe		
26	Limiteur De Débit	Limitatore Di Portata	Flow Limiter		
27	Joint torique 12,5 x3 wras / ktw (1x)	Anello tenuta 12,5x3 WRAS / KTW (1x)	O-ring 12,5x3 WRAS / KTW (1x)		
28	Joint 16x24x2	Guarnizione 16x24x2 (2x)	Rubber seal 16x24x2 (2x)		
29	Circulateur sanitaire	Pompa sanitaria	Pump DHW		
30	Tube Sortie Echangeur A Plaques	Tubo Di Mandata Scambiatore Calore Piast	Pipe Outlet Plate Heat Exchanger		
31	Sonde De Température	Sensore Termometrico	Temperature Sensor		
32	Joint torique 8 x2 (x10)	Anello tenuta 8x2 (10x)	O-ring 8x2 (10x)		
33	Sonde de température NTC	Sonda di temperatura NTC	Temperature sensor NTC		
34	Tube Sortie Eau Chaude Sanitaire	Tubo Uscita Dell'acqua Calda Sanitaria	Pipe Output Hot Water		
35	Joint 18,6x13,5x1,5 (10x)	Guarnizione 18,6x13,5x1,5 (10x)	Gasket 18,6x13,5x1,5 (10x)		
36	Tuyau d evacuation	Tubo flessibile	Hose		
39	Vis	Vite	Screw M 5.0X20 DIN 7985		
<b>6B</b>	<b>Groupe de construction</b>	<b>Gruppo di costruzione</b>	<b>Element of construction</b>		
1	Ballon 48 l.inox	Bollitore ACS Inossidabile 48l.	Tank 48l. Stainless		
2	Sonde De Température	Sensore Termometrico	Temperature Sensor		
3	Ecrou CTN	Dado	Nut		
4	Isolant sonde CTN	NTC Isolante	NTC Insulation		
5	Support Vase Expansion CH	Supporto	Bracket Mounting Holder		
6	Vis M5x12 (10x)	Vite M5x12 (10x)	Screw M5x12 (10x)		
7	Tube Entrée Eau Froide Sanitaire COIL	Tubo Acqua Fredda Sanitaria COIL	Pipe Input Cold Water COIL		
7	Tube Inox Entrée Sanitaire	Tubo Ingresso Sanitario Acciaio Inossida	Stainless Steel Sanitary Inlet Pipe		
8	Filtre (10X)	Filtro (10x)	Filter (10x)		
9	Joint torique 13,87x3,53 (x10)	O-ring 13,87x3,53 (10x)	O-ring 13,87x3,53 (10x)		
11	Clip tube (x10)	Clip a innesto a U (10x)	Clip (10x)		
14	Limiteur De Débit 14 l/min	Inserto regolatore di flusso 14lt	Flow restrictor 14ltr. Pink		
14	Limiteur de débit 10 l/min	Inserto regolatore di flusso 10 l/min	Flow regulator type E-W 10 l/min		
16	Raccord Soupape Sanitaire KTW	Raccordo	Connector		
17	Epingle 18mm (10x)	Molletta di ritenzione 18mm (10x)	Clip 18mm (10x)		
18	Soupape De Sécurité	Valvola Sicurezza	Safety Relief Valve		
19	Bouchon (5x)	Tappo (5x)	Stopper (5x)		

<b>Übersetzungsliste</b>		<b>Traduzione delle descrizioni</b>	
<b>Liste des traductions</b>		<b>List of translations</b>	
Pos	Denomination	Descrizione	Description
20	Vase d'Expansion Sanitaire	Vaso D'Espansione Per Acqua Sanitaria	DHW Expansion Vessel
21	Flexible Sanitaire G3/4	Tubo A Spirale Per Acqua Sanitaria G3/4	DHW Corrugated Pipe G3/4
22	Joint 23,9x17,2x1,5 (10x)	Guarnizione 23,9x17,2x1,5 (10x)	Gasket 23,9x17,2x1,5 (10x)
24	Tube entrée ballon Coil	Tubo Di Ritorno De Recipiente	Pipe Inlet Sanitary Tank
24	Tube inox entrée sanitaire ballon	Tubo Di Ingresso Del Serbatoio Sanitario	Stainless Steel Sanitary Tank Inlet Pipe
30	Tube Sortie Echangeur A Plaques COIL	Tubo Di Mandata Scambiatore Calore Piast	Pipe outlet plate heat exchanger COIL
34	Tube sortie sanitaire (COIL)	Tubo Di Uscita Sanitaria (Serpentino)	Sanitary Outlet Pipe (COIL)
34	Tube Inox Sortie Sanitaire	Tubo Scarico Sanitario Acciaio Inossidab	Stainless Steel Sanitary Outlet Pipe
35	Joint 18,6x13,5x1,5 (10x)	Guarnizione 18,6x13,5x1,5 (10x)	Gasket 18,6x13,5x1,5 (10x)
36	Tuyau d evacuation	Tubo flessibile	Hose
37	Patte Inférieure Support Vase 12L	12 L Vaso Espansione Staffa Inferiore	Lower Bracket Expansion Vessel 12L
38	Patte Support Vase 2L	Supporto Vaso Espansione 2L	2L Expansion Vessel Bracket
39	Vis	Vite	Screw M 5.0X20 DIN 7985
40	Joint torique 17x4 (10x)	O-ring 17x4 (10x)	O-ring 17x4 (10x)
41	Tube Entrée Serpentin	Tubo Scambiatore Di Calore A Serpentino	Coil inlet pipe
42	JOINT TORIQUE 3,53 X 20,22ID	O-Ring 3.53 x 20.22id	O-Ring 3.53 x 20.22id
43	Clip tube (10x)	Clip a innesto a U (10x)	Clip (10x)
44	Canne de puisage EGB RPP	Tubo	Pipe
<b>7A</b>	<b>Groupe de construction</b>	<b>Gruppo di costruzione</b>	<b>Element of construction</b>
1	Robinet 3/4" chauffage	Valvola	Globe valve
2	Raccord	Raccordo di collegamento	Connector
3	Coude Gaz	Gomito A Gas	Gas Elbow
5	Robinet 1/2" sanitaire	Valvola	Globe valve
6	Robinet 3/4" Chauffage	Valvola 3/4"	Heating Cock 3/4"
7	Tubes Disconnecteur	Tubo Disconnectore	Pipe Disconnecteur
8	Joint 6x11x1,5 (x10)	Guarnizione 6x11x1,5 (10x)	Gasket 6x11x1,5 (10x)
9	Disconnecteur	Set Carico Impianto	Filling Loop
10	Vis Taptite M5x8	Vite (10x)	Screw (10x)
11	Joint 23,9x17,2x1,5 (10x)	Guarnizione 23,9x17,2x1,5 (10x)	Gasket 23,9x17,2x1,5 (10x)
12	Joint 18,6x13,5x1,5 (10x)	Guarnizione 18,6x13,5x1,5 (10x)	Gasket 18,6x13,5x1,5 (10x)
13	Joints 18,3x24,3 (10x)	Guarnizione 18,3x24,3 (10x)	Washer 18,3x24,3 (10x)
15	Filtre (10X)	Filtro (10x)	Filter (10x)

**Übersetzungsliste**  
**Liste des traductions**

**Traduzione delle descrizioni**  
**List of translations**

Pos	Denomination	Descrizione	Description		
16	Joint 3/4" (10x)	Guarnizione 3/4" (10x)	Washer 3/4" (10x)		
17	Joint 1/2" (10x)	Guarnizione 1/2" (10x)	Washer 1/2" (10x)		
<b>7B</b>	<b>Groupe de construction</b>	<b>Gruppo di costruzione</b>	<b>Element of construction</b>		
1	Raccord	Raccordo di collegamento	Connector		
2	Raccord	Raccordo di collegamento	Connector		
3	Coude Gaz	Gomito A Gas	Gas Elbow		
5	Raccord	Raccordo di collegamento	Connector		
6	Raccord	Raccordo di collegamento	Connector		
10	Vis Taptite M5x8	Vite (10x)	Screw (10x)		
11	Joint 23,9x17,2x1,5 (10x)	Guarnizione 23,9x17,2x1,5 (10x)	Gasket 23,9x17,2x1,5 (10x)		
12	Joint 18,6x13,5x1,5 (10x)	Guarnizione 18,6x13,5x1,5 (10x)	Gasket 18,6x13,5x1,5 (10x)		
13	Joints 18,3x24,3 (10x)	Guarnizione 18,3x24,3 (10x)	Washer 18,3x24,3 (10x)		
15	Filtre (10X)	Filtro (10x)	Filter (10x)		
<b>7C</b>	<b>Groupe de construction</b>	<b>Gruppo di costruzione</b>	<b>Element of construction</b>		
1	Robinet 3/4" chauffage	Valvola	Globe valve		
2	Raccord	Raccordo di collegamento	Connector		
3	Robinet Gaz	Valvola Gas	Gas Cock		
5	Robinet 1/2" sanitaire	Valvola	Globe valve		
6	Robinet 3/4" Chauffage	Valvola 3/4"	Heating Cock 3/4"		
7	Tubes Disconnecteur	Tubo Disconnettore	Pipe Disconnecteur		
8	Joint 6x11x1,5 (x10)	Guarnizione 6x11x1,5 (10x)	Gasket 6x11x1,5 (10x)		
9	Disconnecteur	Set Carico Impianto	Filling Loop		
10	Vis Taptite M5x8	Vite (10x)	Screw (10x)		
11	Joint 23,9x17,2x1,5 (10x)	Guarnizione 23,9x17,2x1,5 (10x)	Gasket 23,9x17,2x1,5 (10x)		
12	Joint 18,6x13,5x1,5 (10x)	Guarnizione 18,6x13,5x1,5 (10x)	Gasket 18,6x13,5x1,5 (10x)		
13	Joints 18,3x24,3 (10x)	Guarnizione 18,3x24,3 (10x)	Washer 18,3x24,3 (10x)		
15	Filtre (10X)	Filtro (10x)	Filter (10x)		
16	Joint 3/4" (10x)	Guarnizione 3/4" (10x)	Washer 3/4" (10x)		
17	Joint 1/2" (10x)	Guarnizione 1/2" (10x)	Washer 1/2" (10x)		
<b>8A</b>	<b>Groupe de construction</b>	<b>Gruppo di costruzione</b>	<b>Element of construction</b>		
1	HW-SetBC-2	HW-SetBC-2	HW-SetBC-2		
<b>8B</b>	<b>Groupe de construction</b>	<b>Gruppo di costruzione</b>	<b>Element of construction</b>		

**Übersetzungsliste**  
**Liste des traductions**

**Traduzione delle descrizioni**  
**List of translations**

Pos	Denomination	Descrizione	Description		
<b>8C</b>	<b>Groupe de construction</b>	<b>Gruppo di costruzione</b>	<b>Element of construction</b>		
1	HW-SetBC-4	HW-SetBC-4	HW-SetBC-4		
<b>9</b>	<b>Groupe de construction</b>	<b>Gruppo di costruzione</b>	<b>Element of construction</b>		
2	IW-EVD2	IW-EVD2	IW-EVD2		



**Gerätetypen**  
**Types de chaudières**

**Tipo apparecchi**  
**Types of appliances**

Gerät Chaudière Apparecchio Appliance	Bestell-Nr. Numéro de commande N° d'ordine Ordering no.	Land Pays Paese Country	Bemerkungen Remarques Osservazioni Remarks
GB172i-24 T50 R H	7 716 701 567	Belgien	
GB172i-24 T50 R P	7 716 701 571	Belgien	
GB192i-24 T50 S H	7 716 701 566	Belgien	
GB192i-24 T50 S P	7 716 701 570	Belgien	
GB172i.2-24 T50 H	7 716 701 553	Deutschland	
GB172i-24 T50 R H	7 716 701 586	Estland, Lettland, Litauen, Ukraine	
GB172i-24 T50 R H	7 716 701 559	Italien	
GB172i-24 T50 R H	7 716 701 585	Moldau, Rumänien	
GB172i-24 T50 R H	7 716 701 577	Polen	
GB172i-24 T50 R H	7 716 701 574	Slowakei, Tschechien	

Bosch Thermotechnik GmbH  
Sophienstr. 30-32  
D-35576 Wetzlar / Germany

**Buderus**